



**NUMBER:** 24-006-06

**GROUP:** Heating & A/C

**DATE:** August 9, 2006

*This bulletin is supplied as technical information only and is not an authorization for repair. No part of this publication may be reproduced, stored in a retrieval system, or transmitted, in any form or by any means, electronic, mechanical, photocopying, or otherwise, without written permission of DaimlerChrysler Corporation.*

**THIS BULLETIN SUPERSEDES TECHNICAL SERVICE BULLETIN 24-013-05, DATED AUGUST 4, 2005, WHICH SHOULD BE REMOVED FROM YOUR FILES. ALL REVISIONS ARE HIGHLIGHTED WITH **\*\*ASTERISKS\*\*** AND INCLUDE AN ADDITIONAL MODEL, YEAR AND REVISED AB/CS/LX/RS/WK/XK REPAIR PROCEDURE.**

**SUBJECT:**

A/C Cooling Coil Odor

**OVERVIEW:**

This bulletin involves inspecting for leaves and other foreign material, cleaning, and treating the cooling coil and housing.

**MODELS:**

1995 - 2003	(AB)	Ram Van/Wagon
1995 - 2004	(AN)	Dakota
2004 - <b>**2007**</b>	(CS)	Pacifica
1998 - 2003	(DN)	Durango
2002 - <b>**2007**</b>	(DR/DH/D1)	Ram Pickup
2004 - <b>**2007**</b>	(HB)	Durango
2001 - 2006	(JR)	Sebring Convertible/Sebring Sedan/Stratus Sedan
2002 - <b>**2007**</b>	(KJ)	Liberty
1993 - 2004	(LH)	300M/Concorde/LHS/New Yorker/Intrepid/Vision
2005 - <b>**2007**</b>	(LX)	300/ <b>**Charger**</b> /Magnum
2005 - <b>**2007**</b>	(ND)	Dakota
2002	(PG)	PT Cruiser (International Markets)
1995 - 2005	(PL)	Neon/SX 2.0
2001 - <b>**2007**</b>	(PT)	Chrysler PT Cruiser
2001 - <b>**2007**</b>	(RG)	Chrysler Voyager (International Markets)
2001 - <b>**2007**</b>	(RS)	Town & Country/Caravan/Voyager
2001 - 2005	(ST)	Sebring Coupe/Stratus Coupe
1997 - 2006	(TJ)	Wrangler



**Stick with the Specialists™**

2002 - 2006	(VA)	Sprinter
1999 - 2004	(WJ/WG)	Grand Cherokee
2005 - **2007**	(WK/WH)	Grand Cherokee
2006 - **2007**	(XK**/XH)**	Commander

**SYMPTOM/CONDITION:**

Some vehicle operators may experience a musty odor from the A/C system, primarily at start up in hot and humid climates. This odor may be the result of microbial growth on the cooling coil. During normal A/C system operation, condensation forms in and around the A/C cooling coil. When airborne pollutants mix with this condensation, bacteria and fungi growth begins and odor results.

**DIAGNOSIS:**

If the operator describes, or the technician experiences a musty odor when operating the A/C system, perform the appropriate Repair Procedure based on the vehicle model.

**PARTS REQUIRED:**

Qty.	Part No.	Description
AR (3)	05170022AA	Cleaner, A/C Cooling Coil, 8 oz. Bottle Refer To Table For Quantity Required
1	04728942AB	Coating, A/C Cooling Coil, 8 oz. Bottle
AR (1)	82205905	Filter, Cabin Air (CS/RS vehicles)
AR (1)	04596501AB	Filter, Pollen (LX vehicles w/sales code ADB)
AR (1)	05103600AA	Filter, A/C and Heater Unit (VA vehicles)

**A/C COOLING COIL CLEANER REQUIREMENTS BY VEHICLE MODEL**

Number of Bottles Required	Models
2	JR, KJ, PG, PL, PT, ST, TJ, ZB
3	AB, AN, CS, DN, DR/DH/D1, HB, LH, LX, ND, RG, RS, VA, WG, WJ, WK/WH, XK**/XH**

**EQUIPMENT REQUIRED:**

AI-62637 **or 534-62637**	Applicator Tool, teamPSE
	Pliers, Hose Clamp
	Fabricated Cap 15.9 mm (0.625 in.)
	Fabricated Cap 19 mm (0.75 in.)

**AB/CS/LX/RS/WK/XK VEHICLE PROCEDURE:**

1. Open the hood.
2. On LX/RS/\*\*2005 WK/ WH (2006 - 2007 WH/WK/XH/XK vehicles skip to step 8) (AB/CS\*\* vehicles proceed to next step), raise the vehicle on a suitable hoist.
3. Inspect the cooling coil housing drain for leaves or other foreign material that may be blocking the drain.

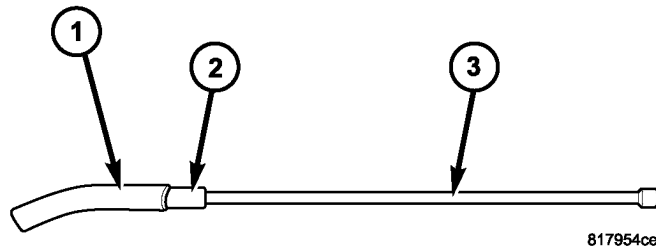

**Fig. 1 FABRICATED PLUG FOR \*\*2005 WK/WH\*\* VEHICLES**

- 1 - 152.4 MM (6 in.) OF 15.9 MM (5/8 in.) I.D. HEATER HOSE, p/n HHR00058AA
- 2 - DEEP 12 MM, 9.8 MM (3/8 in.) DRIVE SOCKET
- 2 - 457.2 MM (18 in.) LONG, 9.8 MM (3/8 in.) DRIVE SOCKET EXTENSION

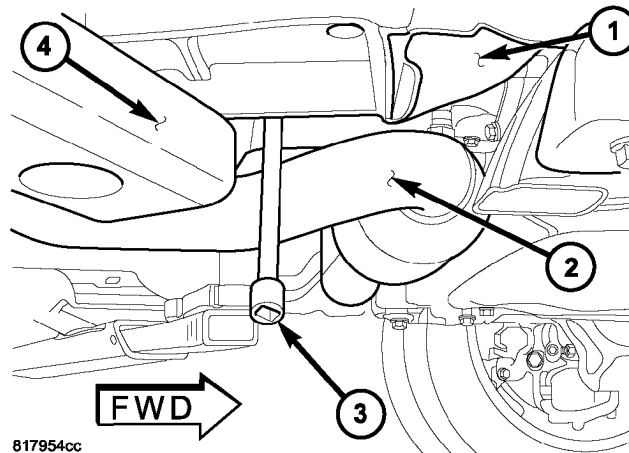

**Fig. 2 FABRICATED PLUG IN PLACE IN \*\*2005 WK/WH\*\* VEHICLES**

- 1 - RIGHT SIDE SUB-FRAME
- 2 - EXHAUST
- 3 - FABRICATED PLUG IN PLACE
- 4 - FORWARD HOIST ARM

4. On **\*\*2005 WK/WH\*\*** vehicles (other vehicles proceed to next step), fabricate the cooling coil drain plug as follows ([Fig. 1](#)):
  - a. Gather a 457.2 mm (18 in.) long, 9.8 mm (3/8 in.) drive socket extension; a deep 12 mm, 9.8 mm (3/8 in.) drive socket, and a 152.4 mm (6 in.) piece of 15.9 mm (5/8 in.) ID heater hose, p/n HHR00058AA
  - b. Place the socket on the end of the extension. Slide approximately 25.4 mm (1 in.) of the heater hose over the socket.
  - c. Slip the heater hose over the cooling coil drain tube, located above the right side of the transmission using the socket and extension to reach up between the frame and the exhaust. Leave the hose socket and extension in place ([Fig. 2](#)). Proceed to [Step #7](#).
5. Cap/clamp off the drain tube using a suitable cap/clamp.
6. AB vehicles proceed to [Step #12](#), other vehicles proceed to next step.
7. On LX/RS/**\*\*2005 WK/WH\*\*** vehicles (other vehicles proceed to next step), lower the vehicle.
8. Remove passenger side floor mat.
9. Place a protective cover over the carpet and the passenger front seat.
10. On LX/RS/**\*\*WH/WK/XH\*\*XK** vehicles (other vehicles proceed to next step), remove the glove box to gain access to the blower motor resistor/power module. Refer to the detailed service information available in TechCONNECT, under: Service Info, 23 - Body, Instrument Panel, Glove Box
11. On LX/**\*\*WH/WK/XH/XK** vehicles , remove the passenger side instrument panel silencer. Refer to the detailed service information available in TechCONNECT, under: Service Info, 23 - Body, Instrument Panel, Instrument Panel Silencer. On 2006 - 2007 WH/WK/XH/XK vehicles remove the blower motor and use a shop vacuum to clean the evaporator coil, reinstall the blower motor and skip to step 18. Other vehicles proceed to next step.\*\*
12. Remove the 2 screws securing the blower motor resistor/power module in the A/C housing and remove the blower motor resistor/power module. Do not disconnect the electrical connector.
13. On LX/**\*\*2005 WK/WH\*\*** vehicles (other vehicles proceed to next step), proceed to [Step #18](#)
14. If the vehicle is not equipped with an A/C air filter, proceed to next step. If equipped with an A/C air filter, remove the A/C air filter. Refer to the detailed service information available in TechCONNECT, under: Service Info, 24 - Heating & Air Conditioning, Distribution, Air Filter.
15. Inspect and remove any leaves and debris.
16. If necessary, use a shop vacuum to clean the cooling coil.
17. If not equipped with an A/C air filter, proceed to next step. If equipped with an A/C air filter, install the air filter door (do not install the air filter at this time).
18. Open all the windows in the vehicle.

**CAUTION: Technician must use eye protection, rubber gloves, protective clothing, and avoid breathing vapors.**

19. Screw the bottle of cooling coil cleaner (p/n 05170022AA) onto the applicator tool.
20. Connect the assembled applicator tool to the shop compressed air supply line.
21. Insert the applicator tool into the blower resistor/power module opening.
22. Spray all of the cooling coil cleaner onto the cooling coil continuously while moving the applicator tool up and down and back and forth so that the evaporator is evenly covered until the required number of bottles are empty (See table for required number of bottles).
23. Allow the vehicle sit for a minimum of 30 minutes.

24. On LX/RS/\*\*2005 WH/WK vehicles, raise the vehicle on a suitable hoist. On 2006 - 2007 WH/WK/XH/XK skip to step 27. Other vehicles proceed to next step.\*\*

**CAUTION: The excess cooling coil coating will drain when the cap/clamp/plug is removed in the next step.**

25. Remove the cap/clamp from the drain tube.
26. On LX/RS/\*\*2005 WH/WK\*\* vehicles (other vehicles proceed to next step), lower the vehicle.
27. Fill each empty cleaner bottle with normal tap water.
28. One at a time, screw each bottle of water onto the applicator tool.
29. Insert the applicator tool into the blower resistor opening.
30. Spray the full contents of the water onto the evaporator continuously while moving the applicator tool up and down and back and forth so that the evaporator is evenly covered with water.
31. Install the blower motor resistor/power module.
32. Start the engine.
33. Raise all the windows to a slightly open position (about 1/2 inch opening).
34. Set the blower to HIGH.
35. Set the A/C switch to A/C OFF.
36. Set mode switch to PANEL OUTLETS.
37. Set temperature switch to FULL HEAT.
38. Set recirculation switch to RECIRCULATE.
39. Allow the blower to operate for 20 minutes.
40. Turn the ignition switch to the OFF position.
41. On LX/RS/\*\*2005 WH/WK vehicles, raise the vehicle on a suitable hoist. On 2006 - 2007 WH/WK/XH/XK skip to step 44. Other vehicles proceed to next step.\*\*
42. Cap/clamp off the drain tube using a suitable cap.
43. On LX/RS/\*\*2005 WH/WK/\*\* vehicles (other vehicles proceed to next step), lower the vehicle.

**CAUTION: Technician must use eye protection, rubber gloves, protective clothing, and avoid breathing vapors.**

44. Open all windows in the vehicle.
45. Remove the blower motor resistor/power module.
46. Shake a 8 ounce bottle of Cooling Coil Coating (p/n 04728942AB), and screw the bottle onto the applicator tool.
47. Insert the applicator tool into the blower resistor opening. Spray the full contents of the bottle onto the evaporator while moving the applicator tool up and down and back and forth so that the evaporator is evenly coated.
48. Allow the vehicle to sit for 30 minutes.
49. Install the blower motor resistor/power module.
50. On LX/RS/\*\*2005 WH/WK vehicles, raise the vehicle on a suitable hoist. On 2006 - 2007 WH/WK/XH/XK skip to step 53. Other vehicles proceed to next step.\*\*

**CAUTION: The excess cooling coil coating will drain when the cap/clamp/plug is removed in the next step.**

51. Remove the drain tube cap/clamp.
52. On LX/RS/\*\*2005 WH/WK\*\* vehicles (other vehicles proceed to next step), lower the vehicle.
53. Start the engine.

54. Raise all the windows to a slightly open position (about 1/2 inch opening).
55. Set the blower to HIGH.
56. Set the A/C switch to A/C OFF.
57. Set mode switch to PANEL OUTLETS.
58. Set temperature switch to FULL HEAT.
59. Set recirculation switch to RECIRCULATE.
60. Allow the engine to run for 20 minutes.
61. Turn the ignition switch to the OFF position.
62. Fill an 8 ounce plastic bottle with warm water and screw onto applicator tool. Clean tool by spraying warm water under pressure into the shop sink. Wipe the tool and store for next use.
63. On LX/RS/\*\*2005 WH/WK vehicles, raise the vehicle on a suitable hoist. On 2006 - 2007 WH/WK/XH/XK skip to step 67. Other vehicles proceed to next step.\*\*

**CAUTION: In the following step be careful not to damage the A/C cooling coil.**

64. Using a suitable object (a wire coat hanger for example), probe the drain tube 3.8 - 5.1 cm (1.5 - 2 in.) to ensure that the dried coil coating is not restricting the flow from the drain tube.
65. AB vehicles proceed to [Step #72](#), CS vehicles proceed to [Step #68](#), LX/RS/\*\*2005 WH/WK\*\* vehicles proceed to [Step #66](#).
66. Lower the vehicle.
67. On \*\*LX/WH/WK/XH/XK\*\* vehicles (RS vehicles proceed to next step), install the right silencer pad.
68. Install the glove box.
69. If the vehicle is not equipped with an A/C air filter, proceed to the next step. If equipped with an A/C filter, remove the air filter door and install the A/C air filter. Replace with a new filter, if necessary. See the parts table for the appropriate part number filter.
70. Remove the carpet and seat protector.
71. Install the floor mat.
72. Close the hood.

**AN/DN/DR/HB/JR/KJ/LH/ND/PL/PT/TJ/WG/WJ VEHICLES PROCEDURE:**

1. Open the hood.
2. Disconnect and isolate the negative battery cable.
3. On AN/DN/HB/JR/LH/PT/WG/WJ - vehicles (other vehicles proceed to the next step), raise the vehicle on a suitable hoist.
4. On AN/DN/ND - vehicles (other vehicles proceed to the next step), remove the exhaust heat shield covering the cooling coil housing drain.
5. Inspect the cooling coil housing drain for leaves or other foreign material that may be blocking the drain.
6. On AN/DN/DR/HB/KJ vehicles (other vehicles proceed to next step), cap off the drain tube using a suitable cap. When the drain tube is capped off, proceed to [Step #9](#).
7. On ND vehicles (other vehicles proceed to next step), plug the cooling coil drain using a piece of plastic or a shop towel. When the drain tube is plugged, proceed to [Step #9](#).
8. Clamp off the drain tube.
9. On AN/DN/HB/JR/LH/ND/PT/WG/WJ - vehicles (other vehicles proceed to the next step), lower the vehicle.
10. Remove passenger side floor mat.
11. Place a protective cover over the carpet and the passenger front seat.
12. If applicable, remove the silencer pad from under the instrument panel on the right side to gain access to the blower motor.

13. On LH vehicles (other vehicles proceed to next step), remove the lower right under panel duct and blower motor cover.
14. Disconnect the blower motor wire harness connector and remove the blower motor.
15. Inspect and remove any leaves and debris.
16. If necessary, use a shop vacuum to clean the cooling coil.
17. Open all the windows in the vehicle.

**NOTE: Technician must use eye protection, rubber gloves, and protective clothing.**

**NOTE: No occupants should be in the vehicle during material application.**

18. Screw the bottle of cooling coil cleaner (p/n 05170022AA) onto the applicator tool.
19. Connect the assembled applicator tool to the shop compressed air supply line.
20. Insert the applicator tool into the blower motor opening. Spray all of the cooling coil cleaner onto the cooling coil until the required number of bottles are empty (See table for required number of bottles).
21. Allow the vehicle to sit for a minimum of 30 minutes.
22. On AN/DN/HB/JR/LH/PT/WG/WJ - vehicles (other vehicles proceed to the next step), raise the vehicle.

**CAUTION: The excess cooling coil coating will drain when the cap/clamp/plug is removed in the next step.**

23. Remove the drain tube clamp/cap/plug.
24. On AN/DN/HB/JR/LH/ND/PT/WG/WJ - vehicles (other vehicles proceed to the next step), lower the vehicle.
25. Fill each empty cleaner bottle with normal tap water.
26. One at a time, screw each bottle of normal tap water onto the applicator tool.
27. Spray all of the normal tap water onto the cooling coil until each bottle is empty.
28. Install the blower motor and connect the blower motor wire harness connector.
29. Connect the negative battery cable.
30. Start the engine.
31. Raise all the windows to a slightly open position (about 1/2 inch opening).
32. Set the blower to HIGH - A/C OFF.
33. Set mode switch to PANEL OUTLETS.
34. Set temperature switch to FULL HEAT.
35. Set recirculation switch to RECIRCULATE.
36. With the engine running, allow the blower to operate for 20 minutes.
37. Turn the ignition switch to the OFF position.
38. On AN/DN/HB/JR/LH/ND/PT/WG/WJ - vehicles (other vehicles proceed to the next step), raise the vehicle.
39. Install the drain tube clamp/cap/plug.
40. On AN/DN/HB/JR/LH/ND/PT/WG/WJ - vehicles (other vehicles proceed to the next step), lower the vehicle.

**CAUTION: Technician must use eye protection, rubber gloves, protective clothing, and avoid breathing vapors.**

41. Open all the windows in the vehicle.
42. Disconnect and isolate the negative battery cable.
43. Disconnect the blower motor wire harness connector and remove the blower motor.

44. Shake an 8 ounce bottle of Cooling Coil Coating (p/n 04728942AB), and screw the bottle onto the applicator tool.
45. Insert the applicator tool into the blower motor opening. Spray the full contents of the bottle on the cooling coil being carefully to cover the entire surface of the cooling coil.
46. Allow the vehicle to sit for 30 minutes.
47. Install the blower motor and connect the blower motor wire harness connector.
48. Connect the negative battery cable.
49. On AN/DN/HB/JR/LH/ND/PT/WG/WJ - vehicles (other vehicles proceed to the next step), raise the vehicle.

**CAUTION: The excess cooling coil coating will drain when the cap/clamp/plug is removed in the next step.**

50. Remove the drain tube clamp/cap.
51. On AN/DN/HB/JR/LH/PT/WG/WJ - vehicles (other vehicles proceed to the next step), lower the vehicle.
52. Start the engine.
53. Raise all the windows to a slightly open position (about 1/2 inch opening).
54. Set the blower to HIGH - A/C OFF.
55. Set mode switch to PANEL OUTLETS.
56. Set temperature switch to FULL HEAT.
57. Set recirculation switch to RECIRCULATE.
58. With the engine running, allow the blower to operate for 20 minutes.
59. Turn the ignition switch to the OFF position.
60. Fill the 4 ounce plastic bottle with warm water and screw onto applicator tool. Clean tool by spraying warm water under pressure into the shop sink. Wipe the tool and store for next use.
61. On AN/DN/HB/JR/LH/ND/PT/WG/WJ - vehicles (other vehicles proceed to the next step), raise the vehicle.

**CAUTION: In the following step be careful not to damage the A/C cooling coil.**

62. Using a suitable object (a wire coat hanger for example), probe the drain tube 3.8 - 5.1 cm (1.5 - 2 in.) to ensure that the dried coil coating is not restricting the flow from the drain tube.
63. On AN/DN/ND - vehicles (other vehicles proceed to the next step), install the exhaust heat shield covering the cooling coil housing drain.
64. On AN/DN/HB/JR/LH/ND/PT/WG/WJ - vehicles (other vehicles proceed to the next step), lower the vehicle.
65. On LH vehicles (other vehicles proceed to next step), install the blower motor cover and lower right under panel duct.
66. Remove the carpet and seat protector.
67. If applicable, install the silencer pad under the right side of the instrument panel.
68. Install floor mat.
69. Close the hood.

***ST VEHICLE PROCEDURE:***

1. Inspect the cooling coil housing drain for leaves or other foreign material that may be blocking the drain.
2. Remove passenger side floor mat.
3. Place a protective cover over the carpet and the passenger front seat.
4. Remove the joint duct. Refer to the detailed service information available in TechCONNECT, under: Service Info, 24 - Heating & Air Conditioning, Blower Assembly and Resistor, Joint Duct.



5. Inspect and remove any leaves and debris.
6. If necessary, use a shop vacuum to clean the cooling coil.

**NOTE: Technician must use eye protection, rubber gloves, protective clothing, and avoid breathing vapors.**

7. Screw the bottle of cooling coil cleaner (p/n 05170022AA) onto the applicator tool.
8. Connect the assembled applicator tool to the shop compressed air supply line.
9. Insert the applicator tool into the opening created by the joint duct removal.
10. Spray the full contents of 2 bottles of cooling coil cleaner onto the evaporator, moving the tool so that the evaporator is completely covered, until both bottles are empty (16 oz. total).
11. Allow the vehicle to sit for a minimum of 30 minutes.
12. Fill both of the empty cooling coil cleaner bottles with normal tap water.
13. Screw one bottle of water onto the applicator tool.
14. Insert the applicator tool into the opening of the heater/cooler unit at the evaporator.
15. Spray the full contents of water until the bottle is empty.
16. Repeat [Step #13](#) through [Step #15](#) using the second bottle of water. When both bottles of water are empty, proceed to the next step.
17. Install the joint duct.
18. Disconnect the A/C clutch electrical connector at the A/C compressor.
19. Start the engine.
20. Set the blower to HIGH - A/C OFF.
21. Set mode switch to PANEL OUTLETS.
22. Set temperature switch to FULL HEAT.
23. Set recirculation switch to RECIRCULATE.
24. Open windows slightly (about 1/2 inch opening).
25. With the engine running, allow the blower to operate for 20 minutes.
26. Turn the engine off.
27. Turn the ignition switch ON, do not start the engine, to allow blower motor operation.
28. Fully open all windows.
29. Remove the outer glove box and the inner glove box. Refer to the detailed service information available in TechCONNECT, under: Service Info, 23 - Body, 23C Body Interior, Instrument Panel

**CAUTION: Technician must use eye protection, rubber gloves, protective clothing, and avoid breathing vapors.**

30. Shake the 8 ounce bottle of Cooling Coil Coating (p/n 04728942AB), and screw the bottle onto the applicator tool.
31. Insert the applicator tool into the recirculation inlet (behind glove box opening). Spray the full contents of the bottle in the airstream until the bottle is empty.
32. Start the engine.
33. Set the blower to HIGH.
34. Set the A/C switch to A/C OFF.
35. Set mode switch to PANEL OUTLETS.
36. Set temperature switch to FULL HEAT.
37. Set recirculation switch to RECIRCULATE.
38. Open windows slightly (about 1/2 inch opening).
39. With the engine running, allow the blower to operate for 20 minutes.
40. Turn the ignition switch to the off position.

41. Fill the 4 ounce plastic bottle with warm water and screw onto applicator tool. Clean tool by spraying warm water under pressure into the shop sink. Wipe the tool and store for next use.
42. Connect the A/C compressor clutch electrical connector at the compressor.
43. Open the right side panel outlet vent.
44. Install inner glove box.
45. Install outer glove box.
46. Remove the carpet and seat protector.
47. Install floor mat.

**VA VEHICLE PROCEDURE:**

1. Raise the vehicle on a suitable hoist.
2. Inspect the cooling coil housing drain for leaves or other foreign material that may be blocking the drain.
3. Clamp off the drain tube using a suitable clamp.
4. Lower the vehicle.
5. Remove the HVAC filter cover and HVAC filter. Refer to the detailed service information available in TechCONNECT, under: Service Info, 24 - Heating & Air Conditioning, Distribution, Air Filter.
6. Inspect and remove any leaves and debris.
7. If necessary, use a shop vacuum to clean the cooling coil.
8. Open all the windows in the vehicle.

**CAUTION: Technician must use eye protection, rubber gloves, protective clothing, and avoid breathing vapors.**

9. Screw the bottle of cooling coil cleaner (p/n 05170022AA) onto the applicator tool.
10. Connect the assembled applicator tool to the shop compressed air supply line.
11. Insert the applicator tool into the HVAC filter opening.
12. Spray all of the cooling coil cleaner onto the cooling coil continuously while moving the applicator tool up and down and back and forth so that the evaporator is evenly covered until the required number of bottles are empty (See table for required number of bottles).
13. Allow the vehicle sit for a minimum of 30 minutes.
14. Raise the vehicle on a suitable hoist.

**CAUTION: The excess cooling coil coating will drain when the cap/clamp/plug is removed in the next step.**

15. Remove the clamp from the drain tube.
16. Lower the vehicle.
17. Fill each empty cleaner bottle with normal tap water.
18. One at a time, screw each bottle of water onto the applicator tool.
19. Insert the applicator tool into the HVAC filter opening.
20. Spray the full contents of the water onto the evaporator continuously while moving the applicator tool up and down and back and forth so that the evaporator is evenly covered with water.
21. Install the HVAC filter cover (do not install the HVAC filter at this time).
22. Start the engine.
23. Raise all the windows to a slightly open position (about 1/2 inch opening).
24. Set the blower to HIGH.
25. Set the A/C switch to A/C OFF.
26. Set mode switch to PANEL OUTLETS.
27. Set temperature switch to FULL HEAT.

28. Set recirculation switch to RECIRCULATE.
29. With the engine running, allow the blower to operate for 20 minutes.
30. Turn the ignition switch to the OFF position.
31. Raise the vehicle on a suitable hoist.
32. Clamp off the drain tube using a suitable clamp.
33. Lower the vehicle.

**CAUTION: Technician must use eye protection, rubber gloves, protective clothing, and avoid breathing vapors.**

34. Open all windows in the vehicle.
35. Remove the HVAC filter cover.
36. Shake a 8 ounce bottle of Cooling Coil Coating (p/n 04728942AB), and screw the bottle onto the applicator tool.
37. Insert the applicator tool into the blower resistor opening. Spray the full contents of the bottle onto the evaporator while moving the applicator tool up and down and back and forth so that the evaporator is evenly coated.
38. Allow the vehicle to sit for 30 minutes.
39. Install the HVAC filter. Replace with a new filter, p/n 05103600AA, if necessary.
40. Install the HVAC filter cover.
41. Raise the vehicle on a suitable hoist.

**CAUTION: The excess cooling coil coating will drain when the cap/clamp/plug is removed in the next step.**

42. Remove the drain tube clamp.
43. Lower the vehicle.
44. Start the engine.
45. Raise all the windows to a slightly open position (about 1/2 inch opening).
46. Set the blower to HIGH.
47. Set the A/C switch to A/C OFF.
48. Set mode switch to PANEL OUTLETS.
49. Set temperature switch to FULL HEAT.
50. Set recirculation switch to RECIRCULATE.
51. With the engine running, allow the blower motor to operate for 20 minutes.
52. Turn the ignition switch to the OFF position.
53. Fill an 8 ounce plastic bottle with warm water and screw onto applicator tool. Clean tool by spraying warm water under pressure into the shop sink. Wipe the tool and store for next use.
54. Raise the vehicle on a suitable hoist.

**CAUTION: In the following step be careful not to damage the A/C cooling coil.**

55. Using a suitable object (a wire coat hanger for example), probe the drain tube 3.8 - 5.1 cm (1.5 - 2 in.) to ensure that the dried coil coating is not restricting the flow from the drain tube.
56. Lower the vehicle.

**POLICY:**

Reimbursable within the provisions of the warranty.

**TIME ALLOWANCE:**

<b>Labor Operation No:</b>	<b>Description</b>	<b>Amount</b>
24-65-02-98	TJ	0.6 Hrs.
	AB,CS,DR,DH,D1,KJ,PL	0.7 Hrs.
	ST, VA	0.8 Hrs.
	JR, LX, PG, PT, RG, RS, WJ, WG, WK, WH, XK	0.9 Hrs.
	HB	1.0 Hrs.
	AN, DN, LH, ND	1.1 Hrs.

**FAILURE CODE:**

ZZ	Service Action
----	----------------