

Distributor/Dealer Service Instructions for:

# Safety Recall No. 821

## Passenger Airbag Module

---

### Models

**2000 (PL) Chrysler Neon**

*NOTE: This recall applies only to vehicles built through January 15, 1999 (MDH011514).*

**IMPORTANT:** Most of the vehicles within the above build period have already been repaired and, therefore, have been excluded from this recall.

**IMPORTANT:** Some of the involved vehicles may be in Distributor/Dealer new vehicle inventory. Distributor/Dealers should also consider this requirement to apply to used vehicle inventory and should perform this recall on vehicles in for service as determined by using the DIAL VIP System.

### Subject

The passenger airbag module on the above vehicles may have been improperly welded. As a result, the passenger airbag may not inflate during an accident.

### Repair

The passenger airbag module must be replaced.

**Parts Information**

**LEFT HAND DRIVE**

Interior Color	Sales Code	Part Code	Part Number
Agate	-AZ	1	QB72LAZAB
Taupe	-L5	2	QB72WL5AB

**RIGHT HAND DRIVE**

Interior Color	Sales Code	Part Code	Part Number
Agate	-AZ	3	QB74LAZAB
Taupe	-L5	4	QB74WL5AB

**Each Distributor/Dealer**, to whom vehicles in the recall were invoiced (or the current Distributor/Dealer at the same street address), will receive enough Passenger Airbag Module Packages to service 100% of those vehicles.

**Distributors/Dealers should determine which parts package is required for each vehicle at the time appointments are scheduled to assure that the correct parts package is available when the customer arrives. The appropriate passenger airbag module package for the vehicle to be serviced may be determined by:**

- Using the part code in the third column of the VIN list along with the above table (involved Distributors/Dealers);
- Using the VIN and part number list electronically transmitted to DIAL System Function 53 (involved Distributors/Dealers); or
- Entering the VIN to DIAL System VIP Function (sales code information) along with the above table (all Distributors/Dealers).

**Service Procedure**

1. With the ignition in the OFF position, disconnect the negative battery cable.

**NOTE: To enhance customer satisfaction, remember to reset the clock when you have completed the service procedure.**

2. Remove the left and right A-pillar trim panels using a trim stick (special tool #C-4755).
3. Remove the two (2) instrument panel top cover screws located in the defroster opening.
4. Lift up on the instrument panel top cover near the cluster bezel and along the rearward edge to disengage the top cover clips.

5. Pull the top cover rearward to disengage the forward pins from the instrument panel, then remove the top cover from the vehicle.

6. Remove the three (3) glove box door screws and then remove the glove box door from the instrument panel.

7. Remove the three (3) passenger airbag cover screws that attach the cover to the top of the instrument panel (Figure1).

8. Remove the two (2) passenger airbag cover screws that attach the cover to the front lower instrument panel (Figure 1).

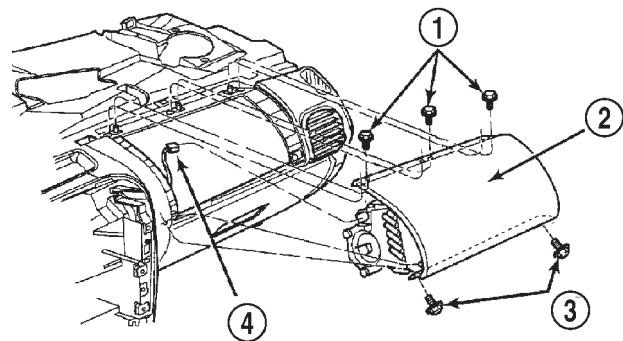

**Figure 1**

1	UPPER AIRBAG COVER SCREWS
2	PASSENGER AIRBAG MODULE
3	LOWER AIRBAG COVER SCREWS
4	AIRBAG MODULE WIRING CONNECTOR

**Service Procedure (Continued)**

9. Remove the three (3) airbag module attaching nuts from the instrument panel support structure (Figure 2).
10. Lift the module up until the wiring connector is visible (Figure 1). Disconnect the 4-way wiring connector by moving the red tab to the unlocked position and then pressing the lock tab.
11. Remove the passenger airbag module from the vehicle. Release the yellow wiring connector lock tab on the side of the module (Figure 3) and then remove and discard the module wiring jumper to insure that the old module DOES NOT inadvertently get installed on any other vehicle. Set the module aside for return to the warranty return center.

**NOTE: Do not attempt to deploy the airbag module. All old airbag modules must be returned to the warranty return center.**

12. Install the new passenger airbag module.

**NOTE: The new module has a [00be]“ diameter green dot on the back of the module near the barcode/warning label to identify it from the old module.**

13. Connect the airbag module wiring connector (Figure 1). Make sure that the red lock tab is in the lock position.

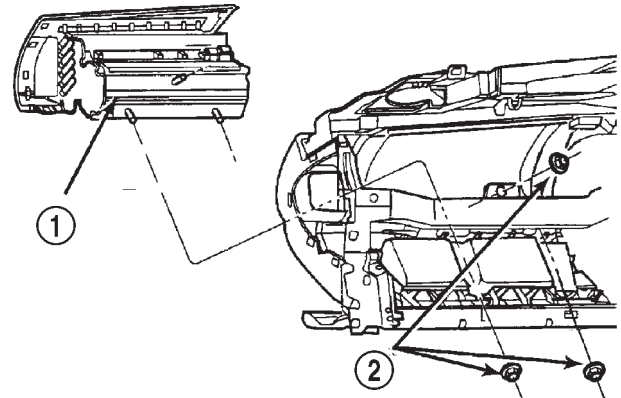

**Figure 2**

1	PASSENGER AIRBAG MODULE
2	AIRBAG MODULE TO I/P SUPPORT NUTS

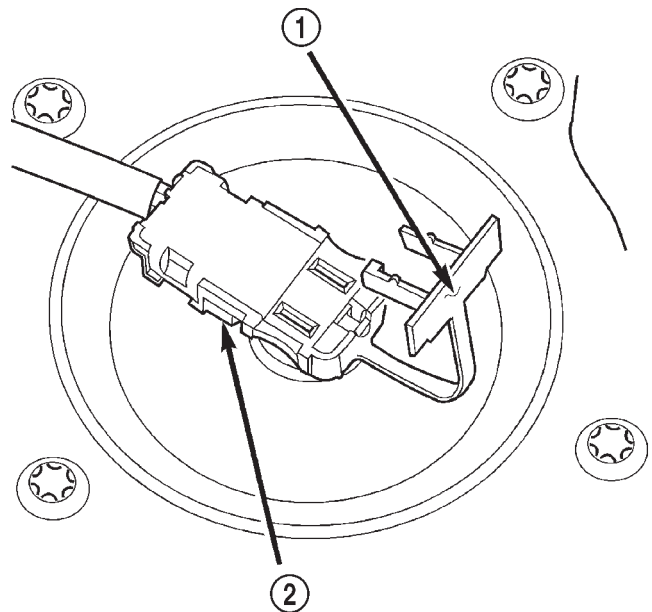

**Figure 3**

1	AIRBAG MODULE WIRING CONNECTOR LOCK TAB
2	RELEASE AIRBAG MODULE CONNECTOR LOCK TAB AND THEN REMOVE AND DISCARD MODULE WIRING JUMPER

**Service Procedures (Continued)**

14. Install the three (3) passenger airbag cover screws that attach the cover to the top of the instrument panel (Figure 1). Tighten the screws to 20 in–lbs (2 N·m).
15. Install the two (2) passenger airbag cover screws that attach the cover to the front lower instrument panel (Figure 1). Tighten the screws to 20 in–lbs (2N·m).
16. Install the three (3) airbag module to instrument panel support structure attaching nuts (Figure 2). Tighten the nuts to 250 in–lbs (28 N·m).
17. Install the glove box door. Tighten the glove box door screws securely.
18. Install the instrument panel top cover. Push the top cover forward to engage the pins with the instrument panel.
19. Press on the instrument panel top cover near the cluster bezel and along the rearward edge to engage the top cover clips.
20. Install the two (2) top cover screws in the defroster opening. Tighten the screws securely.
21. Install the left and right A–pillar trim panels.
22. Turn the ignition switch to the ON position and exit the vehicle.
23. Reconnect the negative battery cable.
24. From outside the vehicle, turn the ignition switch to the OFF position for about 10 seconds and then back to the ON position.
25. Observe the airbag warning light in the instrument cluster. It should illuminate for 6–8 seconds and then go out.

**NOTE: If the airbag warning light fails to light or lights and stays on, there is a system malfunction. Refer to the proper Body Diagnostic Procedures manual to diagnose and repair the problem.**

**Completion Reporting and Reimbursement**

Claims for vehicles that have been serviced must be submitted on the DIAL System. **Claims submitted will be used by DaimlerChrysler to record recall service completions and provide Distributor/Dealer payments.**

Use the following labor operation number and time allowance:

	<b>Labor Operation Number</b>	<b>Time Allowance</b>
Replace the passenger airbag module	08821182	0.4 hours

Add the cost of the recall parts package plus applicable Distributor/Dealer allowance to your claim.

NOTE: See the Warranty Administration Manual, Recall Claim Processing Section for complete recall claim processing instructions

**Parts Return**

**Removed passenger airbag modules must be returned to the Warranty Material Return Center.**

**Distributor/Dealer Notification & Vehicle List**

**Each Distributor/Dealer to whom involved vehicles were invoiced** (or the current Distributor/Dealer at the same street address) **will receive a list of their involved vehicles.** The vehicle list is arranged in Vehicle Identification Number (VIN) sequence. The lists are for Distributor/Dealer reference in arranging for service of involved vehicles.

### **DIAL System Functions 53 and VIP**

All involved vehicles will be entered to DIAL System Functions 53 and VIP at the time of recall implementation for Distributor/Dealer inquiry as needed.

Function 53 provides involved Distributors/Dealers with an updated VIN list of their incomplete vehicles. Completed vehicles are removed from Function 53 within several days of repair claim submission. To use this system, type "53" at the "ENTER FUNCTION" prompt, then type "ORD821".

### **Owner Notification and Service Scheduling**

All involved vehicle owners should be notified of the service requirement by their Distributor/Dealer. Owners are requested to schedule appointments for this service. A sample copy of the owner notification letter is attached.

### **Vehicle Not Available**

If a vehicle is not available for service for a known reason, let us know by describing the reason on a postcard and mail to:

DaimlerChrysler Corporation  
CIMS 482-00-85  
800 Chrysler Drive East  
Auburn Hills, Michigan 48326-2757

Please include the VIN number, campaign number and current owner information, if available.

Following the above procedures will expedite the processing of your claim.

### **Additional Information**

If you have any questions or need assistance in completing this action, please contact your International Service and Parts manager.

# DAIMLERCHRYSLER

## ***SAFETY RECALL TO REPLACE YOUR VEHICLE'S PASSENGER AIRBAG MODULE***

Dear Chrysler Neon Owner:

DaimlerChrysler Corporation has determined that a defect, which relates to motor vehicle safety, exists in some **2000 Chrysler Neon vehicles**.

- The problem is...***      **The passenger airbag module on your Neon may have been improperly welded. As a result, the passenger airbag may not inflate during an accident. This can result in increased injury to a front seat passenger under certain accident conditions.**
- What DaimlerChrysler and your dealer will do...***      **DaimlerChrysler will repair your vehicle free of charge (parts and labor).** To do this, your dealer will replace the passenger airbag module. The work will take about one hour to complete. However, additional time may be necessary depending on how dealer appointments are scheduled and processed.
- What you must do to ensure your safety...***      Simply **contact your dealer** right away to schedule a service appointment. Ask the dealer to hold the parts for your vehicle or to order them before your appointment.
- If you need help...***      If you have trouble getting your vehicle repaired, please contact the DaimlerChrysler Distributor nearest your location. A representative will assist you in getting your vehicle repaired. This information can be found in the Customer Assistance section of your Owner's Manual.

We apologize for any inconvenience, but we are sincerely concerned about your safety. Thank you for your attention to this important matter.

*International Service and Parts  
DaimlerChrysler Corporation  
821*

***Buckle up  
for Safety***