

# Technical Service Bulletin

**NUMBER:** 08-20-00

**GROUP:** Electrical

**DATE:** June 9, 2000

*This bulletin is supplied as technical information only and is not an authorization for repair. No part of this publication may be reproduced, stored in a retrieval system, or transmitted, in any form or by any means, electronic, mechanical, photocopying, recording, or otherwise, without written permission of DaimlerChrysler Corporation.*

**SUBJECT:**

Horn Inoperative Or Sound Is Weak Or Muted

**OVERVIEW:**

This bulletin involves the replacement and reorientation of the horn.

**MODELS:**

2000 (PL) Neon

**NOTE: THIS BULLETIN APPLIES TO VEHICLES BUILT PRIOR TO JUNE 30, 1999 (MDH 0630XX).**

**SYMPTOM/CONDITION:**

Due to horn orientation, water may enter the horn interior and cause damage. The horn may not work or the customer may report that the horn sounds quieter than before.

**DIAGNOSIS:**

Attempt to sound the horn, if the horn is inoperative or sounds muted perform the Repair Procedure.

**PARTS REQUIRED:**

1 05018193AA Horn, Reorientation Package

The kit includes the following items:

- 1 Template
- 1 Horn

If the kit received includes an instruction sheet, please disregard and follow this Technical Service Bulletin.

**EQUIPMENT REQUIRED:**

6.5 mm (.25 in.) Drill Bit  
Angle Drill

**REPAIR PROCEDURE:**

THIS REPAIR IS COMPATIBLE WITH DAIMLERCHRYSLER'S MOBILE SERVICE PROGRAM AND DOES NOT REQUIRE HOISTS OR OTHER FULL SERVICE FACILITY SPECIAL EQUIPMENT

1. Disconnect the battery negative cable.

2. Remove the far right screw of the grill emblem where it attaches to the head lamp module housing.
3. Remove the two screws attaching the right headlamp module to the upper crossmember.
4. Pull the right headlamp module out and remove the connectors.
5. Remove the headlamp module from the vehicle.
6. Disconnect and remove the horn. Discard the horn.
7. Cut out the template provided in the kit.
8. Install the template and hold it in place by inserting the horn mounting bolt in its original position through the template. Mark the location of the new hole through the template.
9. Using a 6.5–mm (.25 in.) drill bit and an angle drill, drill a hole through the sheet metal at the point marked in step 8 (Figure 1).

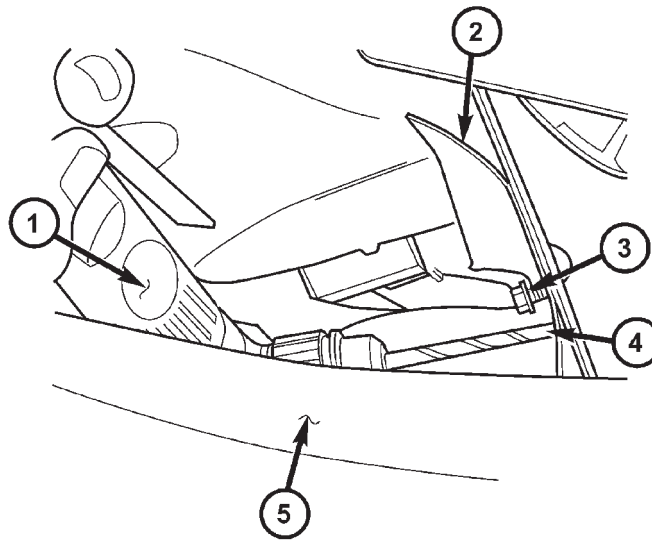

80c64868

**FIGURE 1**

1–	ANGLE DRILL
2–	TEMPLATE
3–	HORN MOUNTING BOLT
4–	DRILL SHOWN IN LOCATION FOR NEW ANTI-ROTATION TAB HOLE
5–	HEADLAMP MODULE HOUSING

10. Position and install the new horn using the original bolt hole. The new hole drilled in step 9 is for the anti–rotation tab on the new horn. The horn will now be approximately horizontal.
11. Install the headlamp module assembly and the grill emblem screw.
12. Install the battery negative cable.

**POLICY:** Reimbursable within the provisions of the warranty.

**TIME ALLOWANCE:**

Labor Operation No: 08-40-01-91..... 0.3 Hrs.

**FAILURE CODE:** P8 – New Part