

WINDSHIELD WIPER and WASHER SYSTEMS

TABLE OF CONTENTS

	page		page
WINDSHIELD WIPER SYSTEM.....	1	WINDSHIELD WASHER SYSTEM.....	8

WINDSHIELD WIPER SYSTEM

TABLE OF CONTENTS

	page		page
GENERAL INFORMATION		WINDSHIELD WIPER BLADE(S)	5
INTRODUCTION	1	WINDSHIELD WIPER BLADE ELEMENT	5
DESCRIPTION AND OPERATION		WINDSHIELD WIPER LINKAGE	5
WIPER BLADES.....	1	WINDSHIELD WIPER MODULE	6
DIAGNOSIS AND TESTING		WINDSHIELD WIPER MOTOR	6
WINDSHIELD WIPER CONDITIONS.....	2	WINDSHIELD WIPER/WASHER SWITCH.....	6
WINDSHIELD WIPER MOTOR	3	CLEANING AND INSPECTION	
WINDSHIELD WIPER/WASHER SWITCH.....	5	WINDSHIELD WIPER BLADE(S)	6
REMOVAL AND INSTALLATION		ADJUSTMENTS	
WINDSHIELD WIPER ARM(S)	5	WINDSHIELD WIPER ARM(S)	6

GENERAL INFORMATION

INTRODUCTION

WARNING: ON VEHICLES EQUIPPED WITH AIR-BAGS, REFER TO GROUP 8M, PASSIVE RESTRAINT SYSTEMS FOR STEERING WHEEL REMOVAL AND INSTALLATION.

The windshield wipers will only operate with the ignition switch in the ACCESSORY or IGNITION RUN position. The wiper circuit is protected against over loads by a fuse in the fuse block and a circuit breaker within the wiper motor. This protects the circuitry of the wiper system and the vehicle. The wiper motor has permanent magnet fields.

The intermittent wiper system, in addition to low and high speed, has a delay mode and a pulse wipe mode. The delay mode has a range of 1 to 15 seconds. Pulse wipe is accomplished by momentarily moving the stalk lever into the WASH position while the wiper switch is in either OFF or DELAY position. The wiper blades then sweep once or twice and return to the previous wiper switch mode, OFF or DELAY.

The intermittent wiper function is integral to the wiper switch. All electronics and relay are inside the switch assembly.

The wiper system completes the wipe cycle when the switch is turned OFF. The blades park in the lowest portion of the wipe pattern.

The wiper switch also includes the MIST feature which provides a single wipe when actuated.

DESCRIPTION AND OPERATION

WIPER BLADES

Wiper blades, exposed to the weather for a long period of time, tend to lose their wiping effectiveness. Periodic cleaning of the wiper blade is suggested to remove the accumulation of salt and road film. The wiper blades, arms, and windshield should be cleaned with a sponge or cloth and a mild detergent or nonabrasive cleaner. If the blades continue to streak or smear, they should be replaced. The right and left wipers are different blade lengths. The driver side length is 550 mm and the passenger side length is 475 mm. The blades should not be interchanged.

DIAGNOSIS AND TESTING

WINDSHIELD WIPER CONDITIONS

WARNING: ON VEHICLES EQUIPPED WITH AIRBAGS, REFER TO GROUP 8M, PASSIVE RESTRAINT SYSTEMS FOR STEERING WHEEL REMOVAL AND INSTALLATION.

The following is a list of general wiper motor system problems, the tests that are to be performed to locate the faulty part, and the corrective action to be taken.

Whatever the problem, disconnect motor wire harness and clean the terminals, then connect motor wire harness and test.

Refer to Group 8W Wiring Diagrams for circuit information and connector call-outs.

MOTOR WILL NOT OPERATE IN SOME OR ALL SWITCH POSITIONS

- (1) Check fuse 1, in the fuse block (Fig. 1).
 - (a) If fuse is OK, go to Step 2.
 - (b) If fuse is defective, replace and check motor operation in all switch positions.
 - (c) If motor is still inoperative and the fuse does not blow, go to Step 2.
 - (d) If replacement fuse blows, go to Step 6.

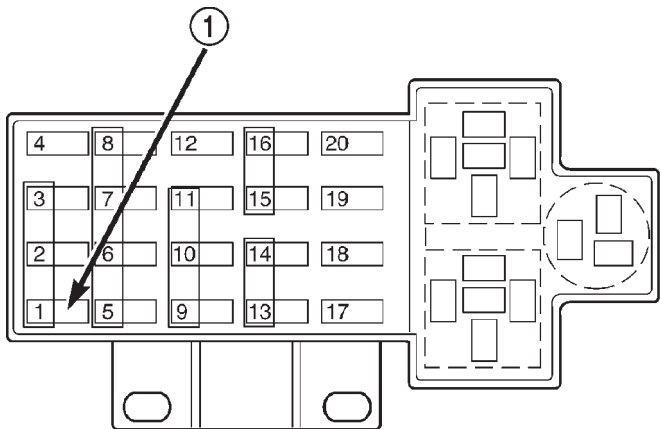

80bcea5f

Fig. 1 Fuse Block

1 - FUSE 1 WIPER

- (2) Disconnect motor harness connector.

(3) Check motor low speed. Using two jumper wires, connect one jumper wire between the battery positive terminal and terminal 4 of the motor connector. Connect the other jumper wire to the battery negative terminal and the motor ground strap (Fig. 2). Check motor high speed, connect the positive jumper wire to terminal 5 of the motor connector. Connect the negative jumper wire to the motor ground strap.

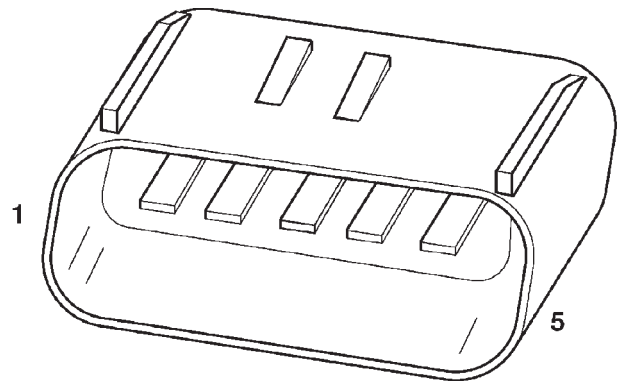

80bcea6c

Fig. 2 Windshield Wiper Motor Connector

- (a) If motor does not run in high or low speed go to Step 4.
- (b) If motor does run, go to Step 5.
- (4) Using an ohmmeter, check for good ground at the motor ground strap. If OK, replace motor. If not repair the ground circuit as necessary.
- (5) Check terminal 2 of wiper switch connector for continuity to ground. If OK, go to Step 6. If not OK, repair the ground circuit as necessary.
- (6) Using a voltmeter, with wiper switch connected, connect negative lead to motor ground strap. Connect the positive lead to terminal 4 of the wiper switch connector (Fig. 3).

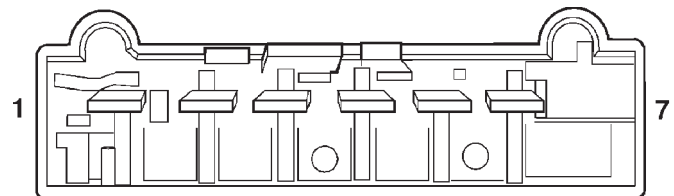

80bcea60

Fig. 3 Windshield Wiper Switch Connector

DIAGNOSIS AND TESTING (Continued)

(a) If no voltage, repair wiring as necessary. If OK, go to Step b.

(b) Check wiper switch low speed. Connect voltmeter positive lead to terminal 6 of the wiper switch connector. Move wiper stalk to LOW position. If no voltage, replace switch.

(c) Check wiper switch high speed, connect voltmeter positive lead to terminal 5 of the wiper switch connector. Move wiper stalk to HIGH position. If no voltage, replace switch.

(7) Disconnect motor connector and replace fuse 1 in fuse block.

(a) If fuse does not blow, replace motor.

(b) If fuse blows, disconnect wiper switch and replace fuse.

(c) If fuse does not blow, replace switch.

(d) If fuse blows, repair wiring as necessary.

MOTOR OPERATES SLOWLY AT ALL SPEEDS

(1) Remove wiper arms and cowl screen. Disconnect motor linkage from motor. Connect an ammeter between battery positive terminal and terminal 4 of the motor connector. Turn wiper motor on and check amperage reading.

If motor runs and ammeter reading is more than 6 amps, go to Step 2. If less than 6 amps, go to Step 3. When replacing drive link nut tighten to 11 to 12 N·m (98 to 106 in. lbs.) torque.

(2) Using an ohmmeter, check the high and low circuits for a short to ground. Refer to Group 8W, Wiring Diagrams.

(3) Check to see if wiper linkage or pivots are binding or caught.

WIPERS RUN AT HIGH SPEED WITH SWITCH IN LOW SPEED POSITION OR WIPERS RUN AT LOW SPEED WITH SWITCH IN HIGH SPEED POSITION.

(1) Check for crossed wires in the motor pigtail wire connector. Refer to Group 8W, Wiring Diagrams.

(2) Check for crossed wires in harness connector from wiper switch to motor.

(3) If OK, replace wiper switch.

WIPERS WILL OPERATE CONTINUOUSLY WITH THE SWITCH IN THE INTERMITTENT POSITION - WHEN WIPER SWITCH IS TURNED OFF, WIPERS STOP WHEREVER THEY ARE WITHOUT RETURNING TO PARK POSITION.

(1) Check at motor ground strap for a good ground.

(2) Turn ignition switch OFF. Disconnect the wiper switch harness connector. Using an ohmmeter with the motor in the park position, check for continuity between terminal 2 of the wiper switch harness connector (Fig. 4) and the ground strap. If continuity, replace wiper switch. If no continuity, repair wiring as necessary.

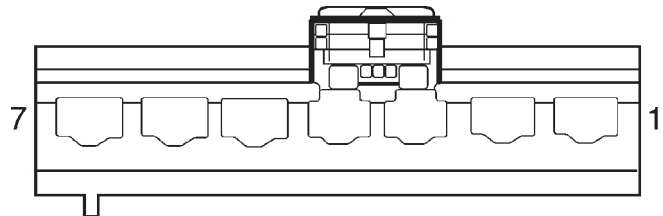

80bbc36b

Fig. 4 Windshield Wiper Switch Harness Connector

WIPERS DO NOT OPERATE WHEN WASHER MOTOR IS ENGAGED (PULSE WIPE) OR WIPERS DO OPERATE IN INTERMITTENT POSITION.

Check for a good ground at motor ground strap and at wiper switch terminal 2. If OK, replace wiper switch. If not OK, repair wiring as necessary.

WINDSHIELD WIPER MOTOR

WARNING: ON VEHICLES EQUIPPED WITH AIR-BAGS, SEE GROUP 8M, RESTRAINT SYSTEMS FOR STEERING WHEEL OR COLUMN REMOVAL PROCEDURES.

Whenever a wiper motor malfunction occurs, verify that the wire harness is properly connected, then start normal diagnosis and repair procedures. Refer to Wiper Motor Test table.

DIAGNOSIS AND TESTING (Continued)

WIPER MOTOR TEST

CONDITION	POSSIBLE CAUSES	CORRECTION
WIPER BLADES DO NOT PARK PROPERLY.	(1) WIPER ARMS IMPROPERLY PARKED. (2) WIPER ARMS ARE LOOSE ON PIVOT SHAFT. (3) MOTOR CRANK LOOSE AT OUTPUT SHAFT.	(1) REMOVE WIPER ARMS AND REPAIR. REFER TO WIPER ARM REMOVAL AND INSTALLATION. (2) REMOVE WIPER ARM AND REPAIR. REFER TO WIPER ARM REMOVAL AND INSTALLATION. (3) REMOVE WIPER ARM, RUN WIPER MOTOR TO PARK POSITION AND REMOVE THE MODULE. WITHOUT ROTATING THE MOTOR OUTPUT SHAFT, REMOVE THE CRANK AND CLEAN ANY FOREIGN MATTER FROM THE MOTOR SHAFT. INSTALL THE MOTOR CRANK IN ITS ORIGINAL POSITION.
MOTOR STOPS IN ANY POSITION WHEN THE SWITCH IS TURNED OFF.	(1) OPEN PARK CIRCUIT.	(1) CHECK PARK SWITCH BY DISCONNECTING THE WIRE CONNECTOR AND APPLY BATTERY VOLTAGE TO PIN 4. PLACE A JUMPER WIRE FROM PIN 2 TO PIN 3 AND THEN TO AN EXTERNAL GROUND. REPLACE MOTOR IF IT DOES NOT PARK.
MOTOR WILL NOT STOP WHEN THE SWITCH IS TURNED OFF.	(1) FAULTY SWITCH. (2) LOCK OF DYNAMIC BRAKE ON WET GLASS.	(1) CHECK SWITCH IN LOW, HIGH AND INTERMITTENT POSITION. (2) ENSURE PARK SWITCH HAS CLEAN GROUND.
WIPER BLADES SLAP AGAINST COWL SCREEN OR WINDOW MOLDINGS.	(1) WIPER ARMS ARE PARKED INCORRECTLY.	(1) PARK WIPER ARMS. REFER TO WIPER ARM ADJUSTMENT.
BLADES CHATTER.	(1) FOREIGN SUBSTANCE SUCH AS POLISH ON GLASS OR BLADES. (2) ARMS TWISTED, BLADE AT WRONG ANGLE ON GLASS. (3) BLADE STRUCTURE BENT. (4) BLADE ELEMENT HAS PERMANENT SET.	(1) CLEAN GLASS AND BLADE ELEMENT WITH NON-ABRASIVE CLEANER. (2) REPLACE ARM. (3) REPLACE BLADE. (4) REPLACE BLADE ELEMENT.
WIPER KNOCK AT REVERSAL.	(1) LINKAGE BUSHINGS WORN. (2) ARMATURE ENDPLAY IN MOTOR.	(1) REPLACE WORN LINK. REFER TO WIPER LINKAGE REMOVAL AND INSTALLATION. (2) REPLACE WIPER MOTOR. REFER TO WIPER MOTOR REMOVAL AND INSTALLATION.
WIPER MOTOR WILL NOT RUN.	(1) BLOWN FUSE. (2) NEW FUSE BLOWS. (3) NEW FUSE BLOWS. (4) NO VOLTAGE AT MOTOR. (5) POOR GROUND.	(1) REPLACE FUSE, AND RUN SYSTEM. (2) CHECK FOR SHORT IN WIRING OR SWITCH. (3) REPLACE FUSE, REMOVE MOTOR CONNECTOR, TURN SWITCH ON, FUSE DOES NOT BLOW, REPLACE MOTOR. (4) CHECK SWITCH AND WIRING HARNESS. REFER TO GROUP 8W, WIRING DIAGRAMS. (5) REPAIR GROUND WIRE CONNECTION AS NECESSARY.

DIAGNOSIS AND TESTING (Continued)

WINDSHIELD WIPER/WASHER SWITCH

To test the switch, first disconnect the switch wires from the body wiring in the steering column. Using an ohmmeter test for continuity between the terminals of the wiper switch. Refer to Group 8T Turn Signal and Hazard Warning Systems, Multi-Function Switch Diagnosis and Testing.

REMOVAL AND INSTALLATION

WINDSHIELD WIPER ARM(S)

REMOVAL

- (1) Place the wiper arm/blades in the PARK position and turn ignition OFF.
- (2) Using a trim stick (special tool #C-4755), gently pry up on arm cap and remove.
- (3) Remove wiper arm retaining nut.
- (4) Remove the arm from the pivot using a rocking motion while the arm is in an over/centered position.
- (5) Clean metal splinters OFF the pivot shafts.

INSTALLATION

For installation reverse above procedures. Before installation activate wiper system to ensure the wiper module is in the PARK position. Position wiper arms so that the heel of the blade(s) is on the park line on the windshield. Refer to Adjustments in this section for Wiper Arm Adjustment.

WINDSHIELD WIPER BLADE(S)

REMOVAL

- (1) Lift wiper arm to the over center position.
- (2) Remove blade assembly from arm by pushing release tab under arm tip and slide blade away from arm tip (Fig. 5).

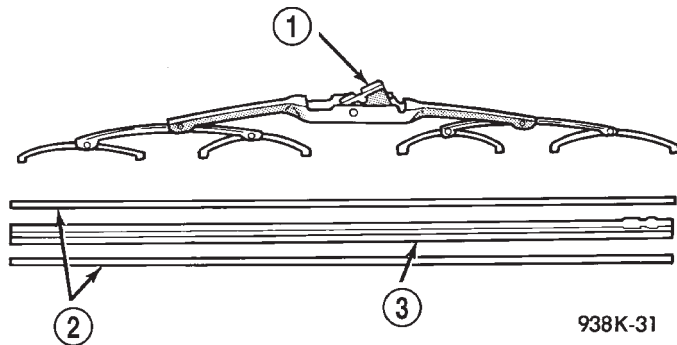

Fig. 5 Windshield Wiper Blade and Element

- 1 - ARM RELEASE TAB
- 2 - VERTABRA
- 3 - RUBBER ELEMENT

- (3) Gently place wiper arm tip on glass surface.

INSTALLATION

For installation, reverse the above procedures.

WINDSHIELD WIPER BLADE ELEMENT

REMOVAL

- (1) Lift wiper arm to raise blade off glass.
- (2) Remove blade assembly from arm by pushing release tab under arm tip and slide blade away from arm tip (Fig. 5). Gently place wiper arm tip on glass surface.
- (3) Remove wiping element from blade assembly. Pull stopper of the rubber element out of the end claw together with vertebrae (metal rails) (Fig. 6).

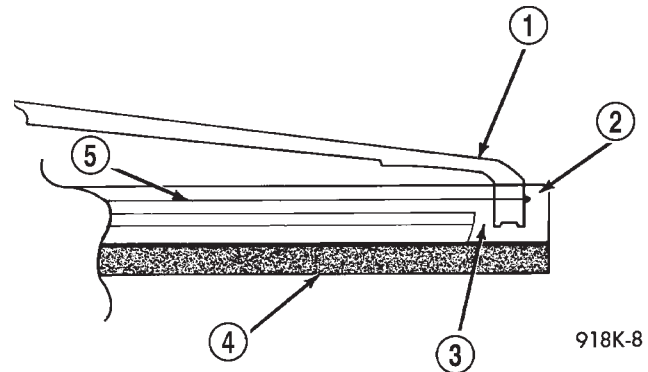

Fig. 6 Wiper Blade and Element

- 1 - CLAW
- 2 - TO GRASP AND PULL
- 3 - CHANNEL
- 4 - RUBBER ELEMENT
- 5 - VERTABRA

INSTALLATION

For installation, reverse the above procedures. Check that the element and vertebrae are through all claws and the final claw is locked in the stopper.

WINDSHIELD WIPER LINKAGE

REMOVAL

- (1) Remove wiper module. Refer to Windshield Wiper Module Removal and Installation in this section.
- (2) With wiper module on bench, disconnect wiper arm linkage by inserting a screwdriver or equivalent between ball cap and linkage. Then twist and lift straight up on linkage.

INSTALLATION

For installation, reverse the above procedures. Using pliers or your hand, press the ball cap straight on to the ball stud.

REMOVAL AND INSTALLATION (Continued)

WINDSHIELD WIPER MODULE

REMOVAL

(1) Disconnect and isolate the battery negative cable (Fig. 7).

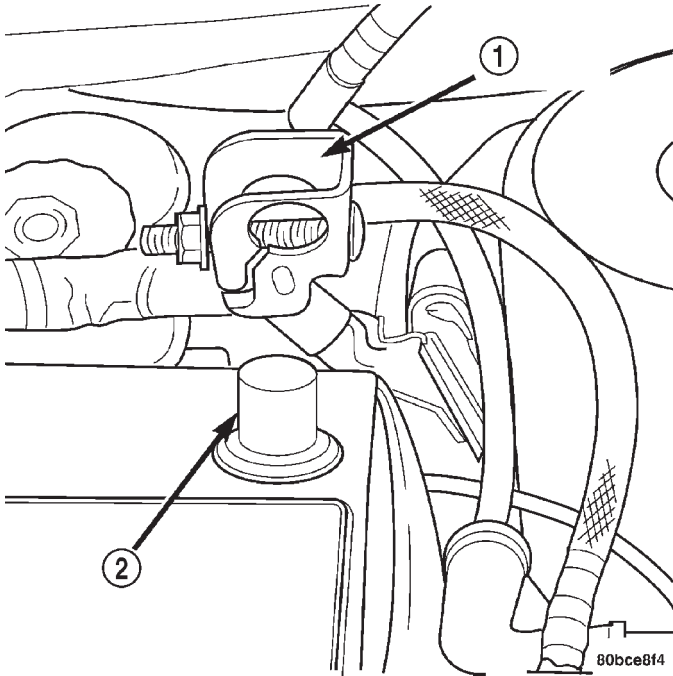

Fig. 7 Battery Negative Cable Remove/Install

- 1 - NEGATIVE CABLE
2 - NEGATIVE BATTERY POST

(2) Remove wiper arms and blades. Refer to Windshield Wiper Arm Removal and Installation in this section.

(3) Remove the left side cowl cover. Refer to Group 23 Body, Cowl Cover Removal and Installation.

(4) Disconnect motor posi-lock harness connector.

(5) Remove windshield wiper module mounting screws and remove module from vehicle.

INSTALLATION

For installation, reverse the above procedures. Tighten the mounting screws to 7 to 9 N·m (60 to 80 in. lbs.) torque.

WINDSHIELD WIPER MOTOR

REMOVAL

(1) Remove windshield wiper module. Refer to Windshield Wiper Module Removal and Installation in this section.

(2) Remove linkage from motor crank. Insert screwdriver or equivalent between crank and linkage then twist and lift straight up on linkage.

(3) Remove three motor mounting screws and separate motor from linkage.

INSTALLATION

For installation add unlube grease to socket and reverse the above procedures. Tighten the motor mounting screws to 5 to 6 N·m (45 to 55 in. lbs.) torque. Tighten drive link nut to 11 to 12 N·m (98 to 106 in. lbs.) torque.

WINDSHIELD WIPER/WASHER SWITCH

To service the wiper switch, refer to Group 8J Turn Signal and Hazard Warning Systems, Multi-Function Switch Removal and Installation.

CLEANING AND INSPECTION

WINDSHIELD WIPER BLADE(S)

Wiper blades exposed to the weather for a long period of time tend to lose their wiping effectiveness. Periodic cleaning of the wiper blade is recommended to remove the accumulation of salt and road grime. The wiper blades, arms and windshield should be cleaned with a sponge or cloth and a mild detergent or nonabrasive cleaner. If the wiper blades continue to streak or smear, they should be replaced. The wiper blade should run smoothly across the windshield in both directions. The wiper blade should slightly roll over center when the blade reverses direction. A wiper blade insert that has lost flexibility or a wiper arm that has lost spring tension, will cause the blade to skip or chatter across the windshield. If the wiper blades are new and the wiper arm spring tension is OK and a chattering sound is emitted from the wiper(s), the wiper blade is not rolling over center. If this condition exists, refer to Adjustments, Wiper Arm Adjustment in this section.

ADJUSTMENTS

WINDSHIELD WIPER ARM(S)

(1) Cycle the wiper motor into the PARK position.
(2) Lift the wiper blade off the windshield and release it.

(3) The wiper blade heel should be parked within 5 mm of the park line. The park line is mark on the windshield (Fig. 9).

(4) In the event that the wiper blade tip excessively strikes the cowl screen due to long term normal wear, reposition the wiper blade heel slightly above the park line. Make sure that the wipers are in the PARK position.

ADJUSTMENTS (Continued)

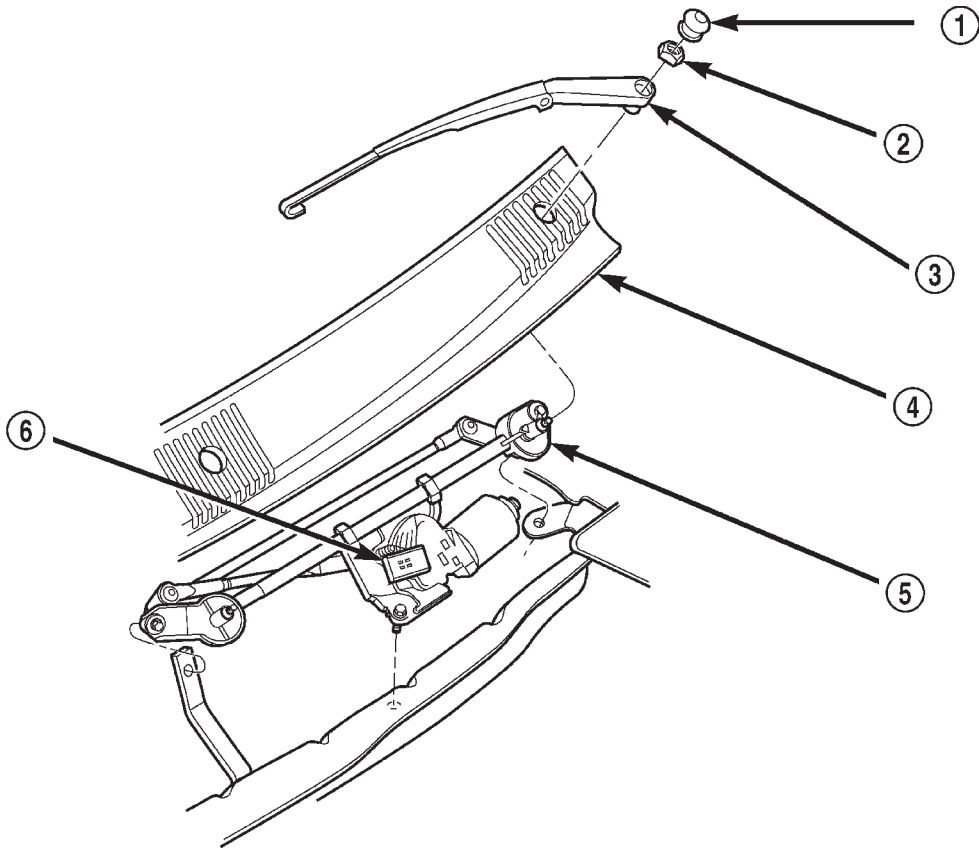

80ae82d0

Fig. 8 Windshield Wiper Module

- | | |
|-------------------|------------------------------|
| 1 - CAPS | 4 - COWL SCREEN |
| 2 - MOUNTING NUTS | 5 - WIPER MOTOR MODULE |
| 3 - WIPER ARM | 6 - INTEGRAL MOTOR CONNECTOR |

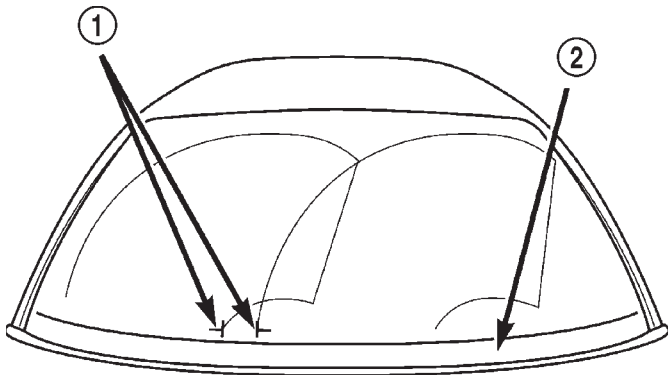

PARK WIPER BLADE HEEL AT PARK

80bcbcea

Fig. 9 Windshield Wiper Blade/Arm Park Lines

- | |
|--------------------|
| 1 - PARK LINES |
| 2 - BLACK OUT AREA |

WINDSHIELD WASHER SYSTEM

TABLE OF CONTENTS

	page	page
DESCRIPTION AND OPERATION		
WINDSHIELD WASHER NOZZLE(S).....	8	
WINDSHIELD WASHER SYSTEM	8	
DIAGNOSIS AND TESTING		
WINDSHIELD WASHER SYSTEM	9	
REMOVAL AND INSTALLATION		
WINDSHIELD WASHER HOSE.....	9	
WINDSHIELD WASHER NOZZLES.....	9	
WINDSHIELD WASHER RESERVOIR.....	10	
WINDSHIELD WASHER PUMP.....	10	

DESCRIPTION AND OPERATION

WINDSHIELD WASHER NOZZLE(S)

This model is equipped with two hood mounted washer nozzles. Each nozzle emits two streams into the wiper pattern (Fig. 1). If the nozzle performance is unsatisfactory they can be adjusted. To adjust insert a pin into the nozzle ball and move to proper pattern (Fig. 2). The right and left nozzles are identical.

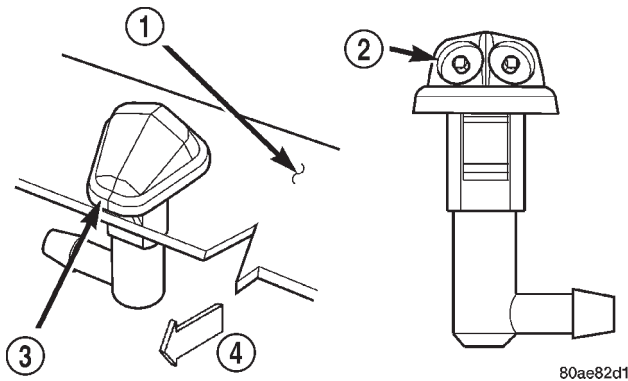

Fig. 1 Windshield Washer Nozzle - Typical

- 1 - HOOD
- 2 - ADJUST WITH A PIN
- 3 - NOZZLE
- 4 - FWD

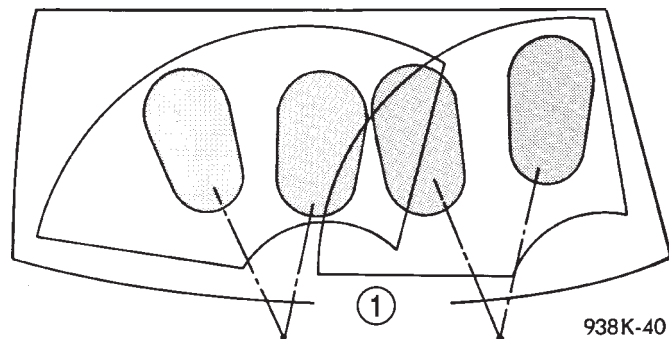

Fig. 2 Windshield Washer Pattern - Typical

- 1 - NOZZLE AIR TARGET

WINDSHIELD WASHER SYSTEM

All models are equipped with electrically operated windshield washer pumps. The wash function can be accessed in the OFF position of the wiper control switch. Holding the wash button depressed when the switch is in the OFF position will operate the wipers and washer motor pump continuously until the washer button is released. Releasing the button will stop the washer pump but the wipers will complete the current wipe cycle. Followed by an average of two more wipe cycles (± 1) before the wipers park and the module turns off.

The electric pump assembly is mounted directly to the reservoir. A permanently lubricated motor is coupled to a rotor type pump. Fluid, gravity fed from the reservoir, is forced by the pump through rubber hoses to the hood mounted nozzles which direct the fluid streams to the windshield.

The pump and reservoir are serviced as separate assemblies (Fig. 3).

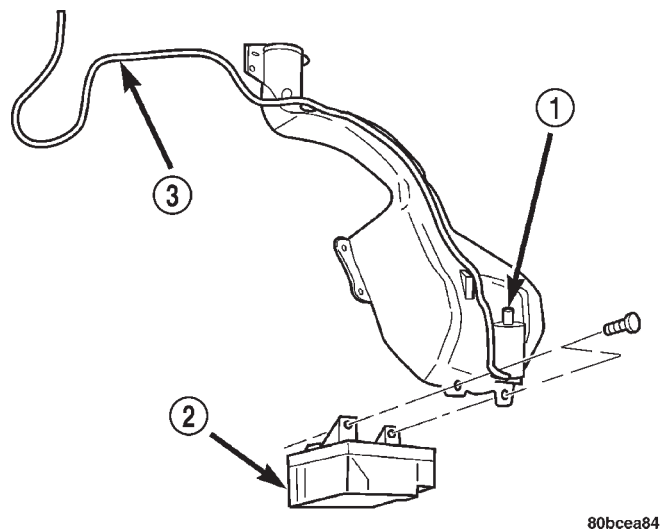

Fig. 3 Windshield Washer Reservoir

- 1 - WINDSHIELD WASHER PUMP
- 2 - SPEED CONTROL VACUUM RESERVOIR
- 3 - WINDSHIELD WASHER HOSE

DIAGNOSIS AND TESTING

WINDSHIELD WASHER SYSTEM

Whenever a windshield washer malfunction occurs, first verify that the windshield washer wire harness

is properly connected to all connectors before starting normal diagnosis and repair procedures. Refer to Windshield Washer System Test table.

WINDSHIELD WASHER SYSTEM TEST

CONDITION	POSSIBLE CAUSE	CORRECTION
PUMP RUNS NO FLUID FLOWING.	1. NO FLUID IN THE RESERVOIR. 2. NOZZLE PLUGGED OR FROZEN. 3. BROKEN, LOOSE OR PINCHED HOSE. 4. FAULTY PUMP.	1. FILL RESERVOIR. 2. THAW AND CHECK FLOW IF BLOCKED 3. CHECK FLOW THROUGH HOSE CONNECTIONS. 4. APPLY BATTERY VOLTAGE TO MOTOR TERMINALS, REPLACE IF PUMP DOES NOT RUN.
SYSTEM OPERATES INTERMITTENTLY.	1. LOOSE WIRE CONNECTION. 2. FAULTY SWITCH.	1. CHECK WIRE CONNECTIONS. 2. DISCONNECT WIRE HARNESS USE VOLTMETER TO CHECK SWITCH.
SYSTEM OUTPUT IS LOW.	1. PINCHED HOSE. 2. HOSE BLOCKED.	1. CHECK FLOW THROUGH HOSE CONNECTION. 2. DISCONNECT HOSE AT NOZZLE AND Y CONNECTOR CHECK FOR FLOW. REPLACE ASS NECESSARY.

REMOVAL AND INSTALLATION

WINDSHIELD WASHER HOSE

REMOVAL

For damaged or plugged windshield washer hose, remove the effected piece of hose and replace routing hose the same way as removed (Fig. 4).

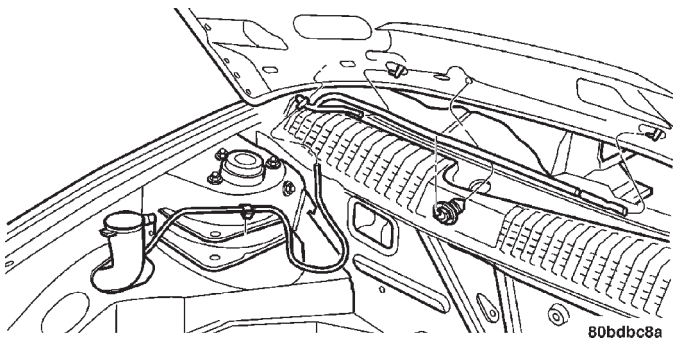

Fig. 4 Windshield Washer Hose

INSTALLATION

For installation, reverse the above procedures.

WINDSHIELD WASHER NOZZLES

REMOVAL

- (1) Open hood.
- (2) Disconnect the windshield washer hose from the underside of the washer nozzle.
- (3) Using a plastic body filler spreader or equivalent (credit card), gently place it underneath the front of the washer nozzle. Be careful not to damage the hood seal underneath the nozzle.
- (4) Rock the nozzle back and forth slightly to release it from the hood panel.

INSTALLATION

- (1) For installation, reverse the above procedures.
- (2) After connecting hose, check for proper system function and to assure leak free connections by actuating the washer system switch from inside of vehicle.

REMOVAL AND INSTALLATION (Continued)

WINDSHIELD WASHER RESERVOIR

REMOVAL

- (1) Raise vehicle on hoist.
- (2) Disconnect the wire connector from the reservoir pump (Fig. 5).

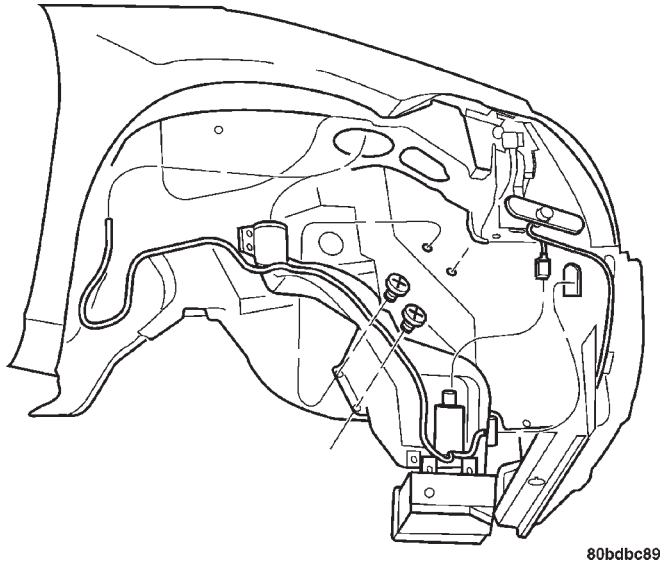

80bdbc89

Fig. 5 Windshield Washer Reservoir Remove/Install

- (3) Disconnect the washer hose at the pump and drain the reservoir.
- (4) Disconnect the vacuum connector to the speed control vacuum reservoir.
- (5) Remove fasteners from reservoir.
- (6) Remove the reservoir through fender opening.
If replacing reservoir, the windshield washer pump and the speed control vacuum reservoir must be transferred to the new washer reservoir.
- (7) Remove two fasteners retaining speed control vacuum reservoir.
- (8) Remove to the windshield washer pump from the reservoir. Refer to Windshield Washer Pump Removal and Installation in this section.

INSTALLATION

For installation, reverse the above procedures. Tighten the reservoir screws to 2.2 to 3.3 N·m (20 to 29 in. lbs.) torque.

WINDSHIELD WASHER PUMP

REMOVAL

- (1) Raise vehicle on hoist.
- (2) Disconnect the wire connector from the reservoir pump.
- (3) Disconnect the washer hose at the pump and drain the reservoir.
- (4) Gently pry pump away from reservoir and out of grommet. Care must be taken not to puncture reservoir (Fig. 6).

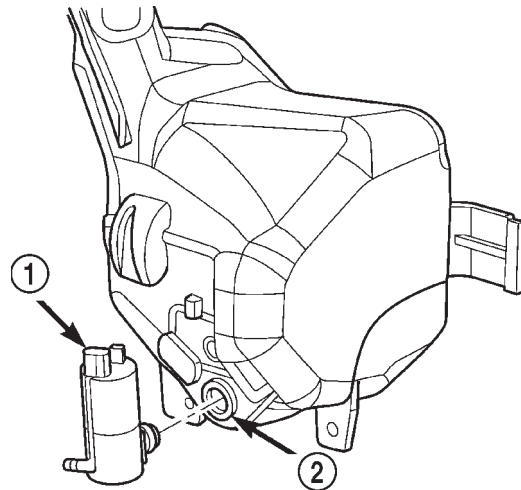

80ac82d3

Fig. 6 Windshield Washer Pump Remove/Install

- 1 - WASHER PUMP
- 2 - RUBBER GROMMET

- (5) Remove rubber grommet from reservoir. If replacing the pump, discard the old washer pump grommet. If replacing the reservoir only, reuse the old washer pump grommet.

INSTALLATION

For installation, reverse the above procedures. Make sure to use new grommet when installing new washer pump.