

# CLUTCH

## TABLE OF CONTENTS

	page		page
<b>DESCRIPTION AND OPERATION</b>		<b>REMOVAL AND INSTALLATION</b>	
MODULAR CLUTCH ASSEMBLY.....	1	CLUTCH CABLE .....	7
CLUTCH CABLE .....	1	CLUTCH INTERLOCK/UPSTOP SWITCH.....	8
CLUTCH INTERLOCK/UPSTOP SWITCH.....	1	MODULAR CLUTCH ASSEMBLY.....	8
<b>DIAGNOSIS AND TESTING</b>		RELEASE BEARING AND FORK .....	12
CLUTCH SYSTEM DIAGNOSIS.....	2	<b>CLEANING AND INSPECTION</b>	
DRIVE PLATE MISALIGNMENT .....	5	CLUTCH CONTAMINATION.....	12
CLUTCH CHATTER COMPLAINTS .....	5	CLEANING PRECAUTIONS .....	13
CLASH-INTO-REVERSE COMPLAINTS .....	5	<b>SPECIFICATIONS</b>	
CLUTCH INTERLOCK/UPSTOP SWITCH.....	5	TORQUE .....	13

## DESCRIPTION AND OPERATION

### MODULAR CLUTCH ASSEMBLY

All 2.0L SOHC engines equipped with the A578 5-speed transaxle use a modular clutch assembly (Fig. 1). The transaxle must be removed to gain access to and replace the modular clutch, drive plate, and/or clutch release bearing and lever.

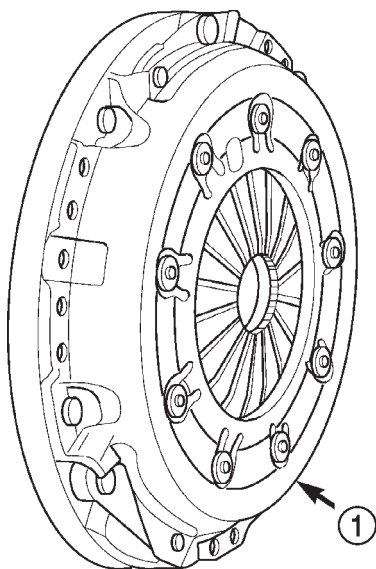

80bc4ee0

**Fig. 1 Modular Clutch Assembly**

1 - MODULAR CLUTCH ASSEMBLY

The modular clutch assembly used in this vehicle consists of a single, dry-type clutch disc, a diaphragm style clutch cover, and an integrated flywheel. The clutch cover is riveted to the flywheel, containing the

clutch disc within. The modular clutch can only be serviced as an assembly.

The clutch disc has cushion springs riveted to the disc hub assembly. The clutch disc facings are riveted to the cushion springs. The facings are made from a non-asbestos material.

The clutch cover pressure plate assembly is a diaphragm type unit with a one-piece diaphragm spring with multiple release fingers. The pressure plate release fingers are preset during manufacture and are not adjustable.

### CLUTCH CABLE

The clutch cable assembly (Fig. 2) carries the movement of the clutch pedal to the clutch release bearing. The cable is designed to maintain tension against the clutch fork, or lever, and has a built in self-adjusting mechanism, which compensates for clutch disc wear.

### CLUTCH INTERLOCK/UPSTOP SWITCH

#### DESCRIPTION

The clutch interlock/upstop switch is an assembly consisting of two switches: an engine starter inhibit switch (interlock) and a clutch pedal upstop switch (Fig. 3). The switch assembly is located in the clutch/brake pedal bracket assembly (Fig. 4), each switch being fastened by four plastic wing tabs.

#### OPERATION

##### Clutch Interlock Switch

The clutch interlock switch prevents engine starter operation and inadvertent vehicle movement with the clutch engaged and the transaxle in gear.

## DESCRIPTION AND OPERATION (Continued)

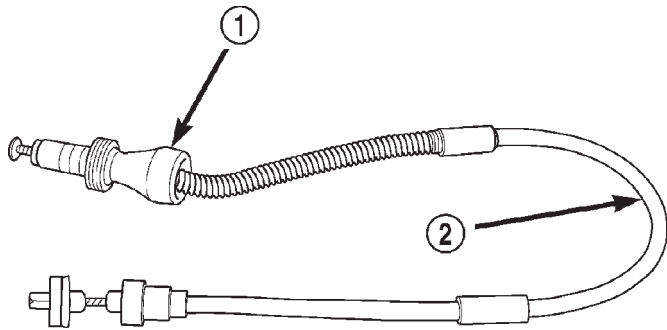

80bc4eee

**Fig. 2 Clutch Cable Assembly**

- 1 - ADJUSTER MECHANISM
- 2 - CLUTCH CABLE

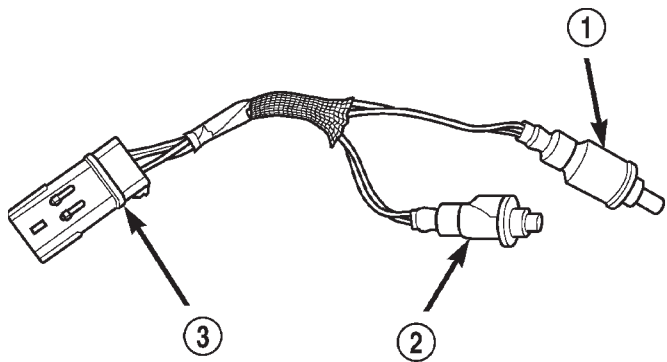

80bc4eea

**Fig. 3 Clutch Interlock/Upstop Switch**

- 1 - UPSTOP SWITCH
- 2 - INTERLOCK SWITCH
- 3 - CONNECTOR

The switch is open while the clutch pedal is at rest. When the clutch pedal is fully depressed, the pedal blade contacts and closes the switch, sending a signal to the PCM, allowing engine starter operation. The interlock switch is not adjustable.

**Clutch Pedal Upstop Switch**

With the clutch pedal at rest, the clutch pedal upstop switch is closed, allowing speed control operation. When the clutch pedal is depressed, the upstop switch opens and signals the PCM to cancel speed control operation, and enter a modified engine calibration schedule to improve driveability during gear-to-gear shifts. The upstop switch is not adjustable.

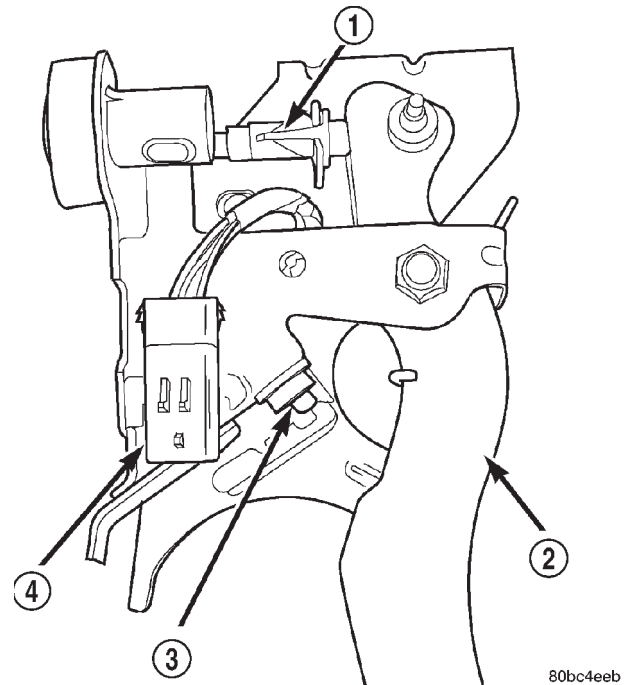

80bc4eeb

**Fig. 4 Clutch/Brake Pedal Bracket Assembly**

- 1 - UPSTOP SWITCH
- 2 - CLUTCH PEDAL
- 3 - INTERLOCK SWITCH
- 4 - CONNECTOR

## DIAGNOSIS AND TESTING

**CLUTCH SYSTEM DIAGNOSIS**

Clutch problem diagnosis will generally require a road test to determine the type of fault. Component inspection will then determine the problem after road testing.

Drive the vehicle at normal speeds during road test. Shift the transaxle through all gear ranges and observe clutch action. If chatter, grab, slip, or improper release is experienced, remove and inspect the clutch components. If the problem is noise or hard shifting, further diagnosis may be needed. The transaxle or other driveline components may actually be at fault.

DIAGNOSIS AND TESTING (Continued)

*SERVICE DIAGNOSIS—CLUTCH GRAB/CHATTER*

<b>CONDITION</b>	<b>POSSIBLE CAUSES</b>	<b>CORRECTION</b>
CLUTCH DISC FACING COVERED WITH OIL OR GREASE	Oil leak at engine rear main or transaxle input shaft seal	Correct leak and replace modular clutch assembly
	Too much grease applied to splines of disc and input shaft	Apply lighter coating of grease to splines
NO FAULT FOUND WITH CLUTCH COMPONENTS	Problem actually related to suspension or driveline component	Further diagnosis required. Check engine/transmission mounts, suspension attaching parts and other driveline components as needed.
	Engine related problems	Check EFI and ignition systems
PARTIAL ENGAGEMENT OF CLUTCH DISC	Clutch cover, spring, or release fingers bent, distorted (rough handling, improper assembly)	Replace modular clutch assembly
	Clutch disc damaged or distorted	Replace modular clutch assembly
	Clutch misalignment	Check alignment and runout of flywheel, disc, or cover. Check clutch housing to engine dowels and dowel holes for damage. Correct as necessary.

*SERVICE DIAGNOSIS—CLUTCH SLIPS*

<b>CONDITION</b>	<b>POSSIBLE CAUSES</b>	<b>CORRECTION</b>
DISC FACING WORN OUT	Normal wear.	Replace modular clutch assembly.
	Driver frequently rides (slips) clutch, results in rapid wear overheating.	Replace modular clutch assembly
	Insufficient clutch cover diaphragm spring tension	Replace modular clutch assembly
CLUTCH DISC FACING CONTAMINATED WITH OIL OR GREASE	Leak at rear main oil seal or transaxle input shaft seal	Replace leaking seals. Replace modular clutch assembly.
	Excessive amount of grease applied to input shaft splines	Apply less grease to input shaft. Replace modular clutch assembly
	Road splash, water entering housing	Seal housing. Inspect clutch assembly.
CLUTCH IS RUNNING PARTIALLY DISENGAGED	Release bearing sticking or binding, does not return to normal running position.	Verify that bearing is actually binding. Then, replace bearing and transmission front bearing retainer if sleeve surface is damaged.
	Cable self-adjuster mechanism sticking or binding causing high preload	Verify that self-adjuster is free to move

## DIAGNOSIS AND TESTING (Continued)

CONDITION	POSSIBLE CAUSES	CORRECTION
CLUTCH DISC FACINGS HAVE FRACTURED INTO SMALL PIECES	Driver performs a 5-1 downshift at vehicle speed in excess of 60 miles per hour	Alert driver to problem cause. Replace modular clutch assembly.
	Leak at rear main or transaxle input shaft seal	Replace modular clutch assembly. Replace seal.
	Excessive heat from slippage	Replace modular clutch assembly

*SERVICE DIAGNOSIS—IMPROPER CLUTCH RELEASE*

CONDITION	POSSIBLE CAUSES	CORRECTION
CLUTCH DISC BINDS ON INPUT SHAFT SPLINES	Clutch disc hub splines damaged during installation	Clean, smooth, and lubricate disc and shaft splines. Replace modular clutch assembly and/or input shaft if splines are severely damaged.
	Input shaft splines rough, damaged.	Clean input shaft splines. Then lube.
	Corrosion or rust formations on splines of input shaft and disc	Clean input shaft splines and disc splines, then lube
CLUTCH DISC RUSTED TO FLYWHEEL AND/OR PRESSURE PLATE	Occurs in vehicles stored or not driven for extended period of time. Also occurs after steam cleaning if vehicle is not used for extended period.	Replace modular clutch assembly
CLUTCH WILL NOT DISENGAGE PROPERLY	Disc bent, distorted during transaxle installation	Replace modular clutch assembly
	Clutch cover diaphragm spring damaged during transaxle installation	Replace modular clutch assembly
	Release fork bent, loose, or damaged	Replace fork if worn or damaged
	Clutch cable binding or routed incorrectly	Check and correct cable routing
	Self-adjuster in cable not functioning properly, resulting in excess cable slack	Pull on cable conduit at transaxle (as if disconnecting cable) to check adjuster operation

*SERVICE DIAGNOSIS—CLUTCH PEDAL NOISE*

CONDITION	POSSIBLE CAUSES	CORRECTION
CLUTCH PEDAL MAKES REPEATED "POP" NOISE IN THE FIRST INCH OF TRAVEL	Self-adjusting mechanism in cable defective	Replace clutch cable
CLUTCH PEDAL SQUEAKS WHEN DEPRESSED TO FLOOR	Pedal bushings worn out or inadequate lubrication	Replace or lubricate bushings
	Clutch pedal return spring worn out	Lubricate or replace return spring
	Clutch release lever pivot stud has inadequate lubrication	Lubricate or replace clutch release lever

DIAGNOSIS AND TESTING (Continued)

**DRIVE PLATE MISALIGNMENT**

Common causes of misalignment are:

- Heat warping
- Mounting drive plate on a dirty crankshaft flange
- Incorrect bolt tightening
- Improper seating on the crankshaft shoulder
- Loose crankshaft bolts

Clean the crankshaft flange before mounting the drive plate. Dirt and grease on the flange surface may misalign the flywheel, causing excessive runout. Use new bolts when mounting drive plate to crankshaft. Tighten drive plate bolts to specified torque only. Over-tightening can distort the drive plate hub causing excessive runout.

**CLUTCH CHATTER COMPLAINTS**

For all clutch chatter complaints, do the following:

(1) Check for loose, misaligned, or broken engine and transmission mounts. If present, they should be corrected at this time. Test vehicle for chatter. If chatter is gone, there is no need to go any further. If chatter persists:

(2) Check to see if clutch cable routing is correct and operates smoothly.

(3) Check for loose connections in drive train. Correct any problems and determine if clutch chatter complaints have been satisfied. If not:

(4) Remove transaxle. See Group 21, Manual Transaxle for procedure.

(5) Check to see if the release bearing is sticky or binding. Replace bearing, if needed.

(6) Check linkage for excessive wear on the pivot stud and fork fingers. Replace all worn parts.

(7) Check clutch assembly for contamination (dirt, oil). Replace clutch assembly, if required.

(8) Check to see if the clutch disc hub splines are damaged. Replace with new clutch assembly, if necessary.

(9) Check input shaft splines for damage. Replace, if necessary.

(10) Check for uneven wear on clutch fingers.

(11) Check for broken clutch cover diaphragm spring fingers. Replace with new clutch assembly, if necessary.

**CLASH-INTO-REVERSE COMPLAINTS**

Certain NV T350 (A-578) manual transaxles are equipped with a reverse brake. It prevents clash when shifting into reverse, but only if the vehicle is not moving. See Group 21, Transaxle for further diagnosis.

(1) Depress clutch pedal to floor and hold. After three seconds, shift to reverse. If clash is present, clutch has excessive spin time, and the reverse brake may not be functioning.

(2) Remove transaxle. See Group 21, Manual Transaxle for procedure.

(3) Check the input shaft spline, clutch disc splines, and release bearing for dry rust. If present, clean rust off and apply a light coat of bearing grease to the input shaft splines. Apply grease on the input shaft splines only where the clutch disc slides. Verify that the clutch disc slides freely along the input shaft spline.

(4) Check to see if the clutch disc hub splines are damaged, and replace with new clutch assembly if required.

(5) Check the input shaft for damaged splines. Replace as necessary.

(6) Check for broken clutch cover diaphragm spring fingers.

(7) Install clutch assembly and transaxle.

**CLUTCH INTERLOCK/UPSTOP SWITCH**

The clutch interlock/upstop switch is an assembly consisting of two switches: an engine starter inhibit switch (clutch interlock) and a clutch pedal upstop switch (Fig. 5). The switch assembly is located in the clutch/brake pedal bracket assembly (Fig. 6), each switch being fastened by four plastic wing tabs.

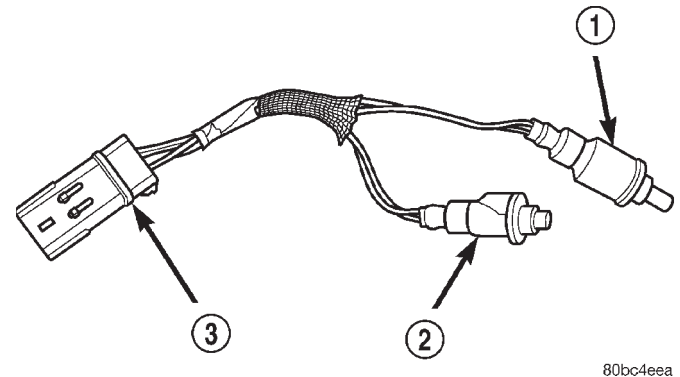

**Fig. 5 Clutch Interlock/Upstop Switch**

- 1 - UPSTOP SWITCH
- 2 - INTERLOCK SWITCH
- 3 - CONNECTOR

**CLUTCH INTERLOCK SWITCH**

**Mechanical Test**

(1) With the park brake set and the transaxle **IN NEUTRAL**, turn the ignition key to the start position. The engine starter should not crank with the clutch pedal at rest (not depressed). If the starter cranks, proceed to the electrical test to determine whether the switch is defective or the circuit is shorted. If the vehicle does not crank, proceed to the next step.

(2) With the park brake set and the transaxle **IN NEUTRAL**, fully depress the clutch pedal and turn

## DIAGNOSIS AND TESTING (Continued)

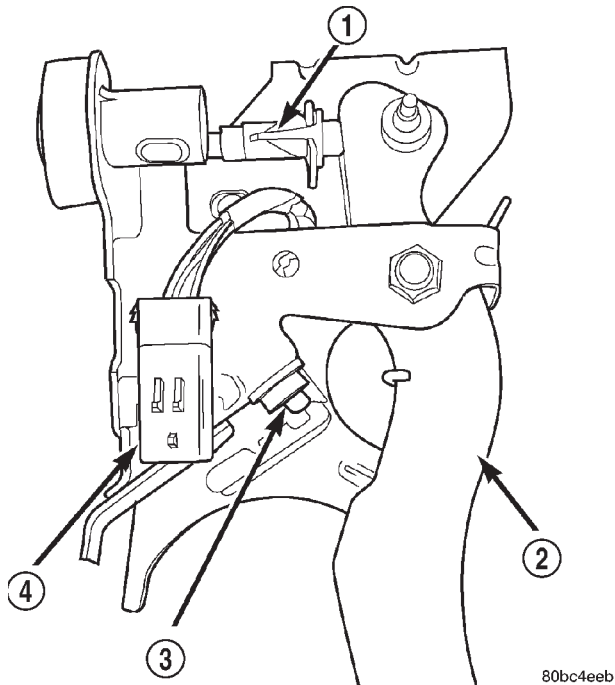

**Fig. 6 Clutch/Brake Pedal Bracket Assembly**

- 1 - UPSTOP SWITCH
- 2 - CLUTCH PEDAL
- 3 - INTERLOCK SWITCH
- 4 - CONNECTOR

the ignition key to the start position. The engine starter should crank. If the starter does not crank, visually inspect the clutch pedal for obstructions (floor mat, etc.). Also make sure the clutch pedal blade contacts and fully

#### Electrical Test

- (1) Move ignition key to the "OFF/LOCK" position and remove key.
- (2) Set park brake.
- (3) Disconnect the clutch interlock/upstop switch connector.
- (4) Using an ohmmeter, check for continuity between terminals 2 & 3 with the interlock switch

not depressed (clutch pedal at rest). There should be no continuity between the terminals (open circuit).

(5) Fully depress the clutch pedal to close the switch at least 1.25 mm (0.050 in.). The ohmmeter should show continuity (0 ohms).

(6) If ohmmeter readings do not fall within these ranges, the switch assembly is defective and should be replaced. If the switch tests ok, wiring is defective. Refer to Group 8W, Wiring Diagrams and repair defective wiring.

#### UPSTOP SWITCH

##### Mechanical Test

- (1) Raise vehicle on hoist.
- (2) Start engine and operate speed control to maintain speed.
- (3) Depress clutch pedal at least 33 mm (1.30 in.). Speed control operation should terminate. If speed control does not terminate, the upstop switch is defective or the related wiring is shorted. Proceed to the upstop switch electrical test.

##### Electrical Test

- (1) Move ignition key to the "OFF/LOCK" position and remove key.
- (2) Set park brake.
- (3) Disconnect the clutch interlock/upstop switch connector.
- (4) Using an ohmmeter, check for continuity between terminals 1 & 2 with the upstop switch depressed (clutch pedal at rest). The ohmmeter should show continuity (0 ohms).
- (5) Depress the clutch pedal at least 33 mm (1.30 in.) check for continuity between terminals 1 & 2. There should be no continuity between the terminals (open circuit).
- (6) If ohmmeter readings do not fall within these ranges, the switch assembly is defective and should be replaced. If the switch tests ok, wiring is defective. Refer to Group 8W, Wiring Diagrams and repair defective wiring.

DIAGNOSIS AND TESTING (Continued)

SERVICE DIAGNOSIS-CLUTCH INTERLOCK/UPSTOP SWITCH

CONDITION	POSSIBLE CAUSES	CORRECTION
ENGINE STARTER WON'T CRANK WHEN CLUTCH PEDAL IS PRESSED TO THE FLOOR	Clutch interlock switch does not have continuity when plunger is depressed 1.25 mm (1.30 in.)	Defective switch or open wiring circuit. Replace switch if necessary.
	Interlock switch plunger is not depressed when clutch pedal is pushed to the floor	Floor mat interferes with clutch pedal movement or clutch pedal bracket is bent.
	Problem is related to other components in the starting circuit.	Check other components in the starting circuit. Refer to Battery/Starting/Charging System in Group 8.
SPEED CONTROL DOES NOT TERMINATE WHEN CLUTCH PEDAL IS DEPRESSED BY AT LEAST 33 mm (1.30 in.)	Upstop switch circuit is closed when clutch pedal is depressed, or harness is shorted.	Refer to Upstop Switch Electrical Test in this group. Repair wiring or replace switch assembly as necessary.
	Other speed control system failure.	Refer to Group 8H, Speed Control for further diagnosis and testing procedures.

REMOVAL AND INSTALLATION

CLUTCH CABLE

REMOVAL

- (1) Disconnect both battery cables.
- (2) Remove battery clamp and remove battery from vehicle.
- (3) Remove battery tray from mount bracket.
- (4) Remove bellhousing cap (Fig. 7).
- (5) Disconnect clutch cable from transaxle housing and clutch release lever as shown in (Fig. 7).
- (6) Disconnect the clutch cable from the clutch pedal spacer (Fig. 8).

**NOTE:** Use care when handling clutch cable assembly. Improper handling can cause adjuster mechanism to come apart, making re-installation difficult.

- (7) Carefully guide cable through pedal assembly bore and remove from vehicle.

INSTALLATION

- (1) Insert the clutch pedal end of the cable into position and connect the cable to the clutch pedal spacer as shown in (Fig. 8).
- (2) Verify adjuster mechanism function as follows:
  - (a) With slight pressure, pull the clutch release lever end of the cable to draw the cable taut.

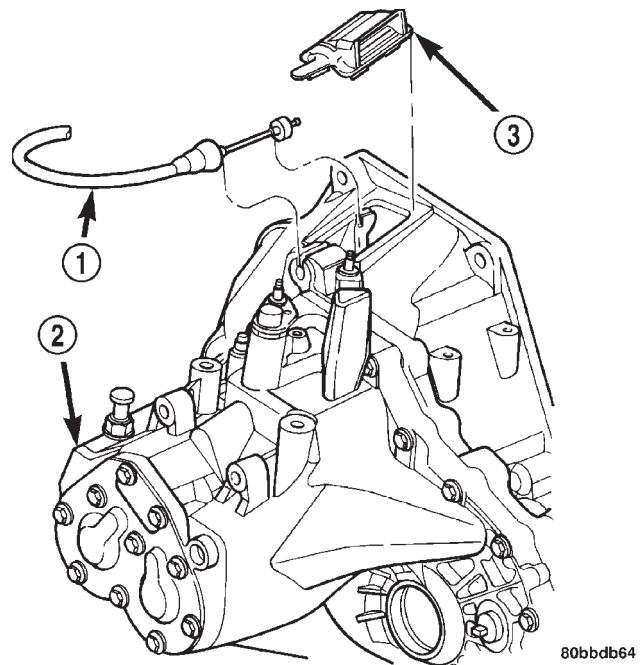
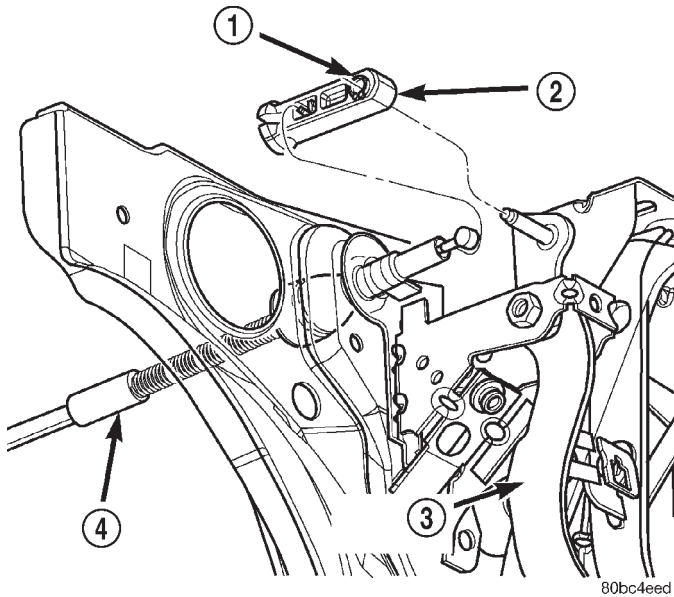

**Fig. 7 Clutch Cable at Transaxle**

- 1 - CLUTCH CABLE
- 2 - TRANSAXLE
- 3 - BELLHOUSING CAP

- (b) Push the clutch cable housing toward the dash panel (With less than 25 lbs. of effort, the cable housing should move 30-50mm.). If the cable

## REMOVAL AND INSTALLATION (Continued)



**Fig. 8 Clutch Cable at Brake/Clutch Pedal Assembly**

- 1 - SNAP RING
- 2 - CLUTCH PEDAL SPACER
- 3 - CLUTCH PEDAL
- 4 - CLUTCH CABLE

housing does not move, it is improperly installed or defective.

(3) Route cable to the transaxle and connect cable end to the clutch release lever and transaxle housing (Fig. 7).

(4) Install bellhousing cap (Fig. 7).

(5) Install and fasten battery tray.

(6) Install battery and hold-down clamp.

(7) Connect both battery cables.

(8) Verify that the clutch cable is working properly.

## CLUTCH INTERLOCK/UPSTOP SWITCH

### REMOVAL

(1) Disconnect and isolate battery negative cable.

(2) Remove instrument panel assembly. Refer to Group 8E, Instrument Panel and Systems for the proper procedure.

(3) Disconnect the clutch interlock/upstop switch connector (Fig. 9).

**NOTE: Proper switch harness routing is critical to switch durability. Note the harness routing and location of fasteners intended to keep wires from contacting pedals.**

(4) Remove the interlock/upstop switch assembly from the brake/clutch pedal bracket assembly by depressing the four plastic wing tabs on each switch.

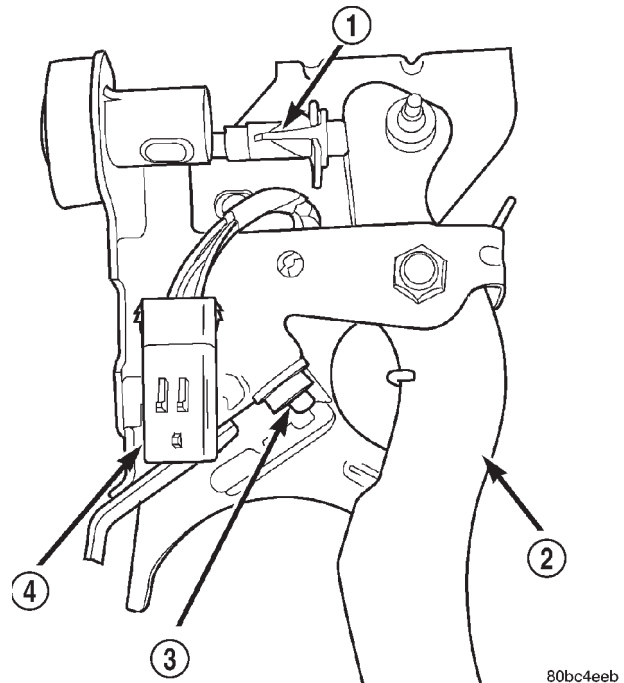

**Fig. 9 Interlock and Upstop Switch Mounting Locations**

- 1 - UPSTOP SWITCH
- 2 - CLUTCH PEDAL
- 3 - INTERLOCK SWITCH
- 4 - CONNECTOR

### INSTALLATION

(1) Install switches into the pedal bracket assembly as shown in (Fig. 9). Route harness as was prior to removal.

(2) Connect interlock/upstop switch connector.

(3) Install instrument panel assembly. Refer to Group 8E, Instrument Panel and Systems for the proper procedure.

(4) Connect battery negative cable.

(5) Verify proper switch operation. Refer to Description and Operation in this Group.

## MODULAR CLUTCH ASSEMBLY

### REMOVAL

(1) Raise hood.

(2) Disconnect and isolate both battery cables, remove battery hold down clamp and bolt, and remove battery.

(3) Remove air cleaner/throttle body assy. (Fig. 10) as follows:

(a) Disconnect proportional purge solenoid (PPS) and crankcase vent hose from throttle body.

(b) Disconnect the Throttle Position Sensor (TPS) and Idle Air Control (IAC) connectors.

(c) Disconnect throttle body air duct at intake manifold.

## REMOVAL AND INSTALLATION (Continued)

(d) Remove mounting bolt and nut (Fig. 10) and partially remove air cleaner assembly.

(e) Disconnect accelerator and speed control (if equipped) cables after the assy. is removed from position. Remove air cleaner assembly from vehicle.

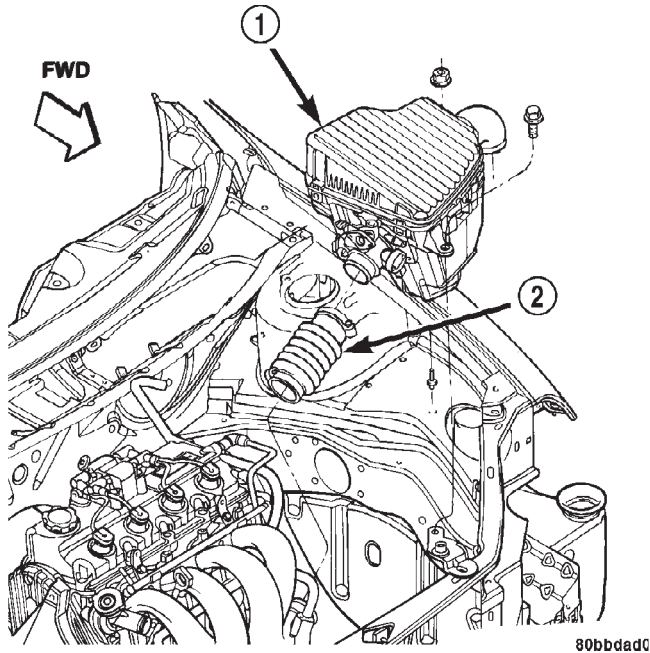

**Fig. 10 Air Cleaner Assembly Removal/Installation**

- 1 - AIR CLEANER ASSY.  
2 - THROTTLE BODY DUCT

(4) Remove battery tray from bracket.  
(5) Disconnect ground cable at battery tray bracket.

(6) Disconnect back-up lamp switch connector.

(7) Remove bellhousing cap (Fig. 11).

(8) Disconnect clutch cable from release lever and remove from transaxle (Fig. 11).

(9) Remove shift cable-to-bracket clips (Fig. 12).

(10) Disconnect shift selector and crossover cable from levers (Fig. 12). Remove cables and secure out of the way.

(11) Disconnect the vehicle speed sensor connector (Fig. 13).

(12) Raise vehicle on hoist.

(13) Remove transaxle oil drain plug and drain oil into a suitable container.

(14) Remove both axle shafts. Refer to Group 3, Differential and Driveline for the correct procedures.

(15) Remove structural collar (Fig. 14).

(16) Remove the left engine-to-transaxle lateral bending brace (Fig. 14).

(17) Remove bellhousing dust cover (Fig. 14).

(18) Remove the right engine-to-transaxle lateral bending brace (Fig. 15).

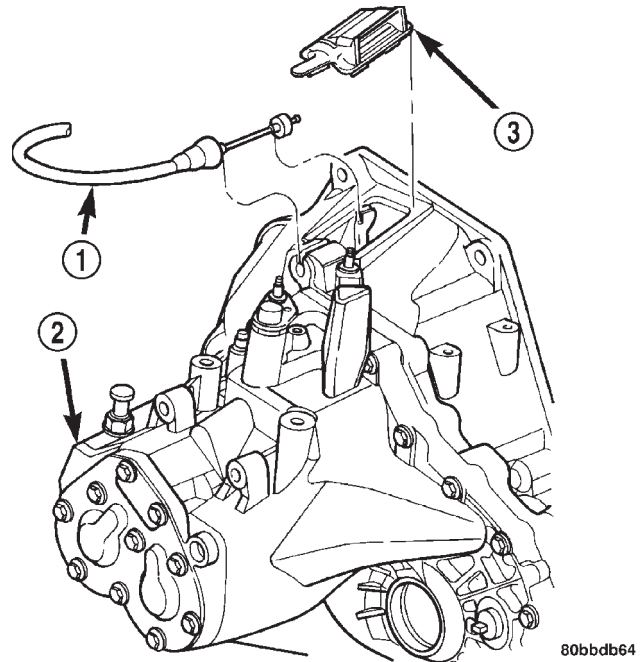

**Fig. 11 Clutch Cable at Transaxle**

- 1 - CLUTCH CABLE  
2 - TRANSAXLE  
3 - BELLHOUSING CAP

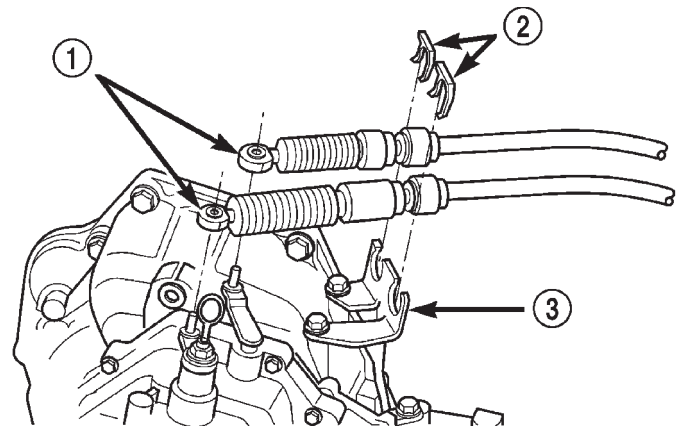

**Fig. 12 Shift Cables at Transaxle**

- 1 - SHIFT CABLES  
2 - CLIPS  
3 - BRACKET

(19) Remove starter motor (Fig. 16).

(20) Remove drive plate-to-clutch module bolts.

(21) Support engine at oil pan with screw jack and wood block.

(22) Remove transaxle upper mount thru-bolt. Gain access to this bolt through the driver's side wheel house (Fig. 17).

(23) Carefully lower engine and transaxle on screw jack until proper removal clearance is obtained.

## REMOVAL AND INSTALLATION (Continued)

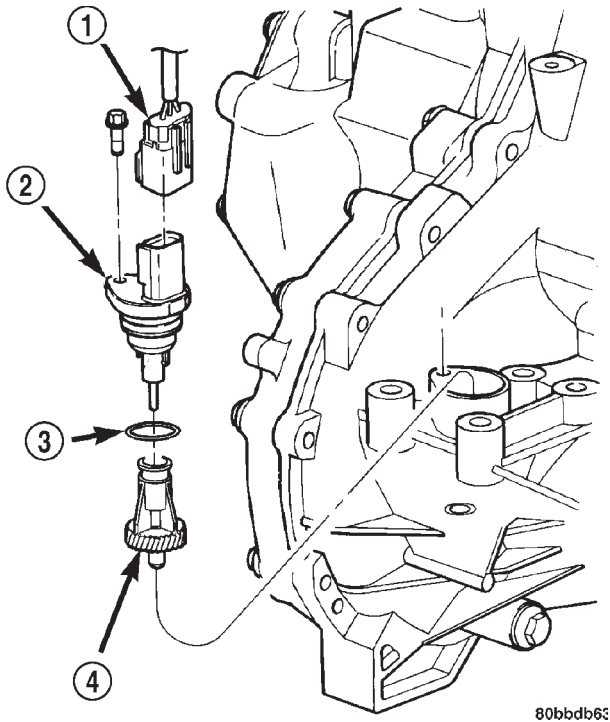

80bbdb63

**Fig. 13 Vehicle Speed Sensor Connector**

- 1 - CONNECTOR
- 2 - SENSOR
- 3 - O-RING
- 4 - SPEEDO PINION

(24) Obtain a helper to assist in holding transaxle while removing transaxle-to-engine mounting bolts (Fig. 18).

(25) Remove transaxle from vehicle (Fig. 18).

(26) Remove modular clutch assembly from transaxle input shaft.

**INSTALLATION**

(1) Inspect clutch release bearing and lever for excessive wear and replace as necessary.

(2) Install clutch module onto input shaft. Install transaxle into position.

(3) Install transaxle-to-engine mounting bolts (Fig. 18) and tighten to 95 N·m (70 ft. lbs.) torque.

(4) Raise engine and transaxle with screw jack until through hole in upper mount aligns with hole in mount bracket. Install mount bolt and tighten to 108 N·m (70 ft. lbs.) torque (Fig. 17).

(5) Remove screwjack.

(6) Install NEW drive plate-to-clutch module bolts and progressively tighten all bolts in a criss-cross pattern until the modular clutch assembly seats against the drive plate. Final torque the bolts to 88 N·m (65 ft. lbs.) torque.

(7) Install starter motor and tighten bolts to 54 N·m (40 ft. lbs.) torque. Make sure to fasten ground cable to upper starter bolt as shown in (Fig. 16).

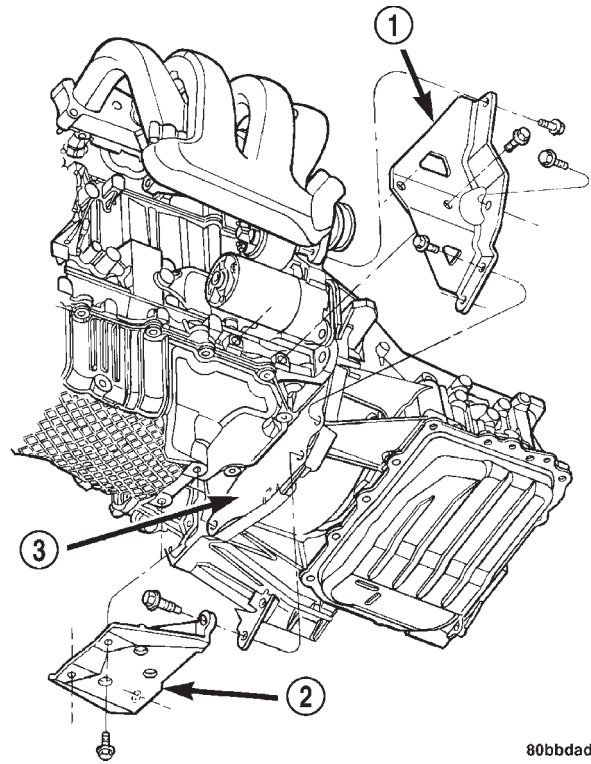

80bbdad2

**Fig. 14 Left Lateral Bending Brace and Structural Collar—Typical**

- 1 - LATERAL BENDING BRACE
- 2 - STRUCTURAL COLLAR
- 3 - DUST COVER

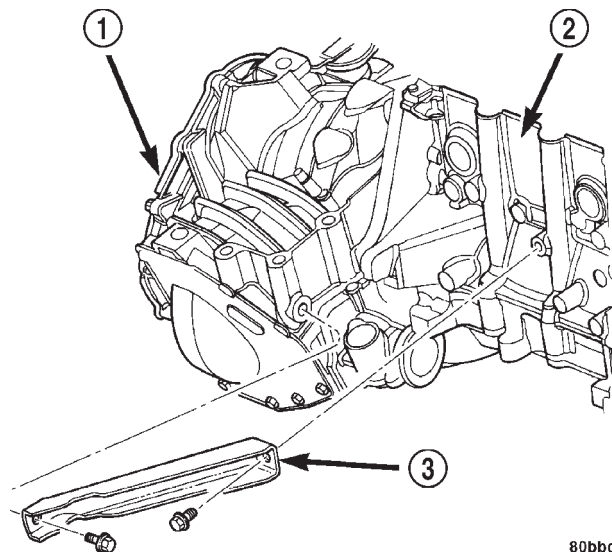

80bbdad1

**Fig. 15 Right Lateral Bending Brace Removal/Installation—Typical**

- 1 - TRANSAXLE
- 2 - ENGINE
- 3 - LATERAL BENDING BRACE

REMOVAL AND INSTALLATION (Continued)

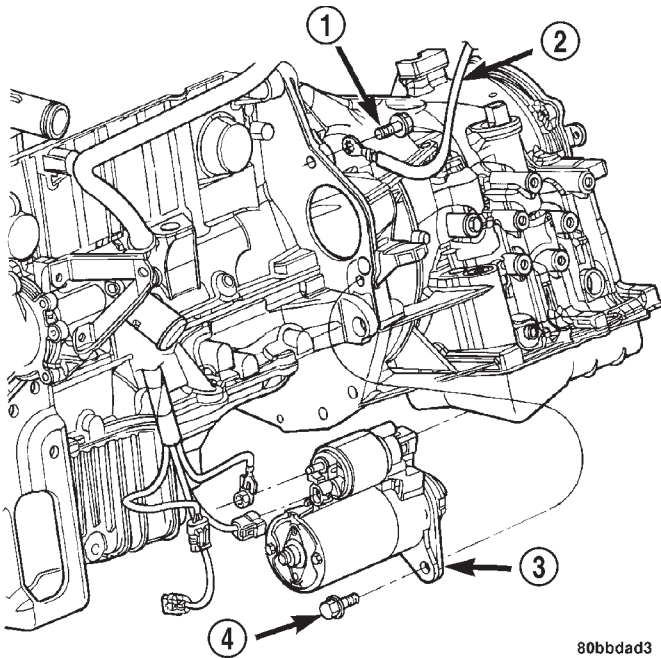

**Fig. 16 Starter Motor Removal/Installation—Typical**

- 1 - BOLT
- 2 - GROUND
- 3 - STARTER
- 4 - BOLT

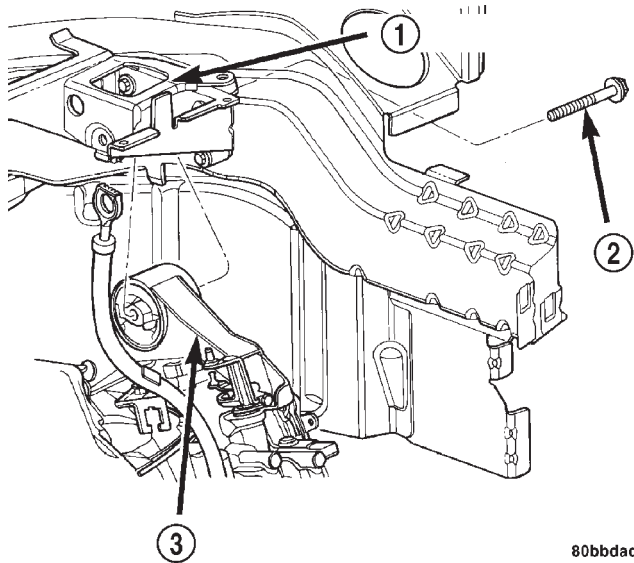

**Fig. 17 Transaxle Upper Mount Thru-Bolt—Typical**

- 1 - MOUNT BRACKET
- 2 - BOLT
- 3 - MOUNT

- (8) Connect starter electrical harness and tighten positive cable nut to 10 N-m (90 in. lbs.) torque.
- (9) Install bellhousing dust cover (Fig. 14).
- (10) Install left engine-to-transaxle bending brace (Fig. 14).

- (11) Install structural collar (Fig. 14) as follows:
  - (a) Position collar and install all bolts finger tight.
  - (b) Tighten the collar-to-oil pan bolts to 3 N-m (30 in. lbs.) torque.
  - (c) Tighten the collar-to-transaxle bolts to 108 N-m (80 ft. lbs.) torque.
  - (d) Final torque the collar-to-oil pan bolts to 54 N-m (40 ft. lbs.) torque.
- (12) Install the right lateral bending brace and tighten bolts to 81 N-m (60 ft. lbs.) torque (Fig. 15).
- (13) Install both front axle driveshafts. Refer to Group 3, Differential and Driveline for the correct procedures.
- (14) Fill transaxle with suitable amount of Mopar® Manual Transaxle Lubricant (PN 04874465).
- (15) Lower vehicle.
- (16) Connect vehicle speed sensor connector (Fig. 13).
- (17) Connect shift crossover and selector cables to shift lever. Install cables to bracket and install retaining clips (Fig. 12).
- (18) Connect clutch cable to fork and secure to transaxle (Fig. 11).
- (19) Install bellhousing cap (Fig. 11).
- (20) Connect back-up lamp switch connector.
- (21) Connect ground strap to transaxle upper mount bracket.
- (22) Install battery lower tray and battery, and tighten battery hold down clamp to secure battery.
- (23) Install the air cleaner/throttle body assy. as follows:
  - (a) Connect the accelerator and speed control (if equipped) cables to the air cleaner/throttle body assy.
  - (b) Install assy into position, making sure the air cleaner locating slot is engaged to the battery bracket tab, and tighten fasteners to 14 N-m (120 in. lbs.) torque.
  - (c) Verify throttle body duct is fully seated to intake manifold and tighten clamp to 5 N-m (40 in. lbs.) torque.
  - (d) Connect the Throttle Position Sensor (TPS) and Idle Air Control (IAC) connectors.
  - (e) Connect proportional purge solenoid (PPS) and crankcase vent hose from throttle body.
- (24) Connect the battery cables.
- (25) Road test vehicle and inspect for leaks.

## REMOVAL AND INSTALLATION (Continued)

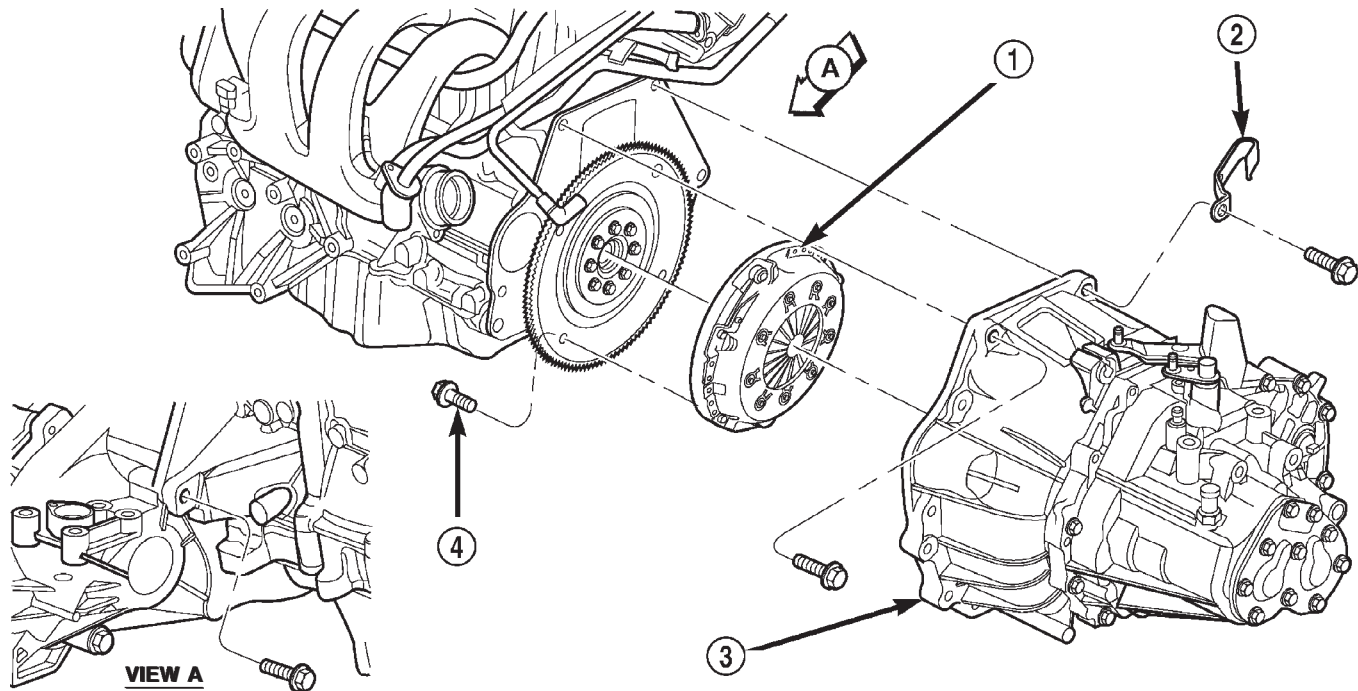

80b30661

**Fig. 18 Transaxle Removal/Installation**

1 - MODULAR CLUTCH ASSEMBLY  
2 - CLIP

3 - TRANSAXLE  
4 - CLUTCH MODULE BOLT (4)

**RELEASE BEARING AND FORK**

Remove the transaxle from the vehicle. See Group 21, Transaxle for removal and installation procedures.

**REMOVAL**

(1) Move the lever and bearing assembly to a vertical in-line position. Grasp the release lever with two hands in the pivot stud socket area. Pull with even pressure and the lever will pop off the pivot-stud. Do not use a screwdriver or pry bar to pop off the lever. This may damage the spring clip on the lever.

(2) As a unit, remove the fork from the bearing thrust plate. Be careful not to damage retention tabs on bearing.

(3) Examine the condition of the bearing. **It is pre-lubricated and sealed and should not be immersed in oil or solvent.**

(4) The bearing should turn smoothly when held in the hand under a light thrust load. A light drag caused by the lubricant fill is normal. If the bearing is noisy, rough, or dry, replace the complete bearing assembly with a new bearing.

(5) Check the condition of the pivot stud spring clips on back side of clutch fork. If the clips are broken or distorted, replace the clutch fork.

**INSTALLATION**

(1) The pivot ball pocket in the fork, as well as the fork arms should be lubricated with grease prior to installation.

(2) Assemble the fork to the bearing. The small pegs on the bearing must go over the fork arms.

(3) Slide the bearing and fork assembly onto the input shaft bearing retainer, as a unit.

(4) Snap the clutch fork onto the pivot ball.

(5) Reinstall transaxle assembly. Refer to Group 21, Transaxle for further information.

**CLEANING AND INSPECTION****CLUTCH CONTAMINATION**

Fluid contamination is a frequent cause of clutch malfunctions. Oil, grease, water, or other fluids on the clutch contact surfaces will cause faulty operation.

During inspection, note if any components are contaminated. Look for evidence of oil, grease, or water/road splash on clutch components.

**OIL CONTAMINATION**

Oil contamination indicates a leak at the rear main seal and/or transaxle input shaft. Oil leaks produce a residue of oil on the transaxle housing interior, clutch

CLEANING AND INSPECTION (Continued)

cover and flywheel. Heat buildup caused by slippage can bake the oil residue onto the components. This glaze-like residue ranges in color from amber to black.

**GREASE CONTAMINATION**

Grease contamination is usually a product of over-lubrication. During clutch service, apply only a small amount of grease to the input shaft splines. Excess grease may be thrown off during operation, contaminating the disc.

**ROAD SPLASH/WATER CONTAMINATION**

Road splash contamination is usually caused by driving the vehicle through deep water puddles. Water can be forced into the clutch housing, causing clutch components to become contaminated. Facing of disc will absorb moisture and bond to the flywheel and/or, pressure plate, if vehicle is allowed to stand for some time before use. If this condition occurs, replacement of clutch assembly may be required. Drive the vehicle until normal clutch operating temperature has been obtained. This will dry off disc assembly, pressure plate, and flywheel.

**CLEANING PRECAUTIONS**

Condensation from steam vapors tend to accumulate on the internal clutch mechanism when the vehicle is steam cleaned. Facing of disc will absorb moisture and will bond to flywheel and/or pressure plate, if vehicle is allowed to stand for some time before use. If this condition occurs, it may require replacement of clutch assembly. After cleaning, drive the vehicle to its normal clutch operating temperature. This will dry off disc assembly, pressure plate, and flywheel.

**SPECIFICATIONS**

**TORQUE**

<b>DESCRIPTION</b>	<b>TORQUE</b>
Modular Clutch-to-Drive Plate Bolts . . . . .	88 N·m (65 ft. lbs.)
Transaxle-to-Engine Mounting Bolts . . . . .	95 N·m (70 ft. lbs.)

