

# BRAKES

## TABLE OF CONTENTS

	page		page
<b>REMOVAL AND INSTALLATION</b>		<b>MASTER CYLINDER – R. H. D. . . . . .</b>	<b>3</b>
POWER BRAKE VACUUM BOOSTER –		<b>SPECIFICATIONS</b>	
R. H. D. . . . . .	1	TORQUE SPECIFICATIONS . . . . .	4

### REMOVAL AND INSTALLATION

#### POWER BRAKE VACUUM BOOSTER – R. H. D.

##### REMOVAL

(1) Disconnect the positive and negative battery cables.

**CAUTION:** Pump the brake pedal several times to relieve the vacuum in the power brake booster. This will prevent the booster from sucking in any contamination when the master cylinder is removed.

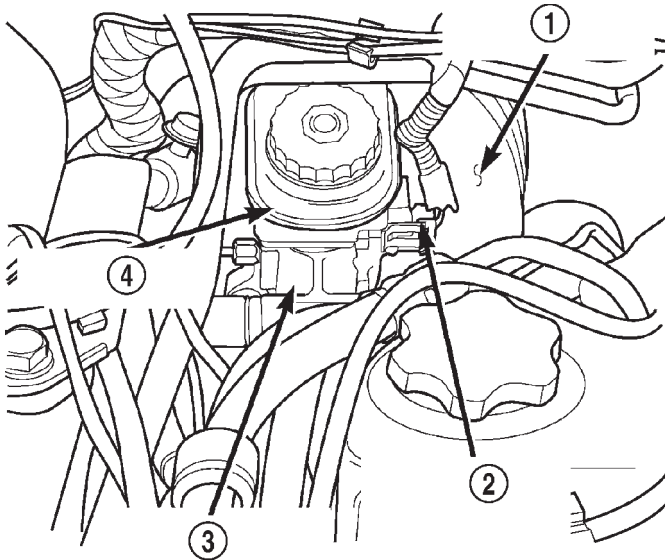

80bc4cb9

**Fig. 1 Brake Master Cylinder**

- 1 – POWER BRAKE VACUUM BOOSTER
- 2 – BRAKE FLUID LEVEL SENSOR ELECTRICAL CONNECTOR
- 3 – BRAKE MASTER CYLINDER
- 4 – BRAKE FLUID RESERVOIR

- (2) Disconnect the brake fluid level sensor electrical connector (Fig. 1).
- (3) Disconnect the booster vacuum supply line from the booster check valve.
- (4) Remove the brake lines from the master cylinder (Fig. 1).
- (5) Remove the (2) master cylinder retaining nuts (Fig. 1).
- (6) Slide the master cylinder assembly straight out of the power brake booster.
- (7) Remove the air cleaner assembly.
- (8) Remove the battery and battery tray from the vehicle.

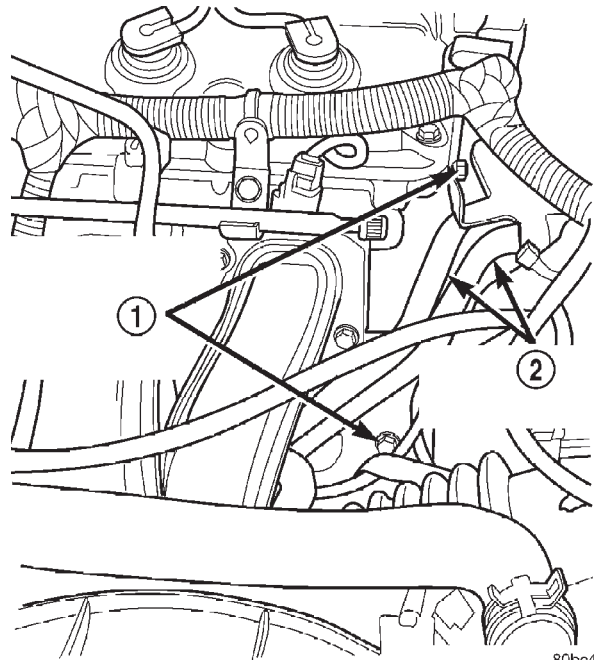

80bc4cc2

**Fig. 2 Heater Core Coolant Supply Lines**

- 1 – HEATER CORE COOLANT LINE SUPPORT BRACKETS BOLTS
- 2 – HEATER CORE COOLANT SUPPLY LINES

(9) Remove the heater core coolant supply tube support bracket bolts (Fig. 2).

## REMOVAL AND INSTALLATION (Continued)

(10) Remove the (2) coolant reservoir retaining bolts from the dash panel. Disconnect the coolant overflow hose from the thermostat housing and remove the coolant reservoir from the dash panel.

(11) Working from underneath the instrument panel, disconnect the brake pedal push rod. Remove the retaining clip from the end of the brake pedal mounted stud, then slide the push rod straight off the pin.

(12) Disconnect the clutch pedal push rod. Depress the plastic retention clip on the end of the clutch pedal mounted stud, while sliding the push rod straight off the stud.

(13) Rotate the clutch master cylinder to line up the square shaped retaining boss with the square shaped opening in the brake pedal support bracket.

(14) Remove the (4) brake booster retaining nuts.

(15) Working from inside the engine compartment, remove the (2) clutch fluid reservoir retaining bolts from the dash panel.

(16) Remove the clutch master cylinder from the dash panel by pulling it straight out. Position the reservoir and line assembly out of the way.

(17) Remove the brake booster from the dash panel by pulling it straight out, then rotate the booster and slide it between the engine and the dash panel towards the battery tray. Slide the booster under the heater core coolant supply hoses and out of the engine bay.

## INSTALLATION

(1) Position the brake booster on the dash panel by reversing the path taken to remove the booster. Slide the booster under the plenum on the battery tray side of the engine compartment. Slide the booster between the engine and dash panel until it can be installed on the right side of the dash panel.

(2) Reinstall the vacuum supply hose on the booster check valve. Make sure the booster check valve is firmly seated in the rubber grommet and did not become dislodged during the booster installation.

(3) Install the clutch master cylinder through the dash panel.

(4) Install the clutch fluid reservoir. Torque the retaining bolts to 7 N·m (62 in. lbs.).

(5) Working from underneath the instrument panel, install the (4) brake booster retaining nuts. Torque the nuts to 29 N·m (250 in. lbs.).

(6) Grease the brake pedal pin and slide the brake booster push rod onto the pedal pin. Install the retaining clip.

(7) Lock the clutch master cylinder in position. Rotate the clutch master cylinder to line up the square shaped retaining boss with the square shaped opening in the brake pedal support bracket. Once the

cylinder is inserted through the brake pedal support bracket rotate 90° to lock it in position.

(8) Connect the clutch pedal push rod. Slide the push rod on the clutch pedal mounted stud until the plastic retention clip locks it in place.

(9) Install the coolant reservoir. Torque the retaining bolts to 7 N·m (62 in. lbs.). Connect the coolant overflow hose on the thermostat housing.

(10) Install the heater core coolant supply tube support bracket bolts. Torque the bolts to 36 N·m (27 ft. lbs.).

(11) Install the battery and battery tray in the vehicle.

(12) Install the air cleaner assembly.

**CAUTION:** Be certain the vacuum seal is installed in the master cylinder mounting flange before installation.

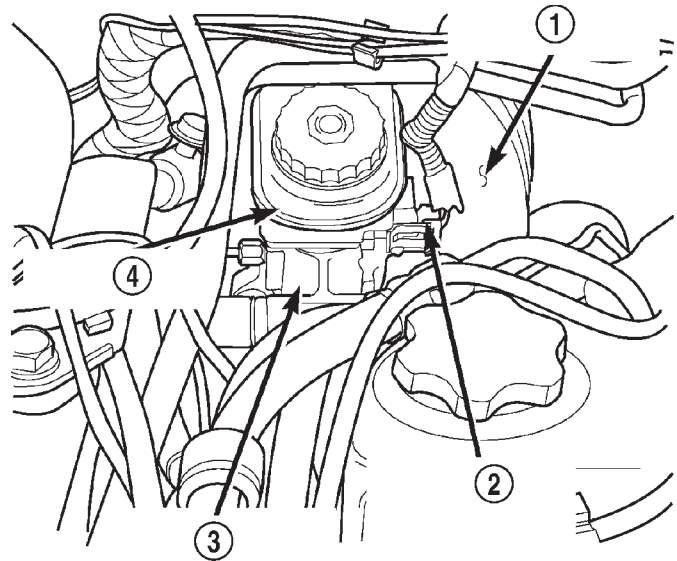

80bc4cb9

**Fig. 3 Brake Master Cylinder**

- 1 - POWER BRAKE VACUUM BOOSTER
- 2 - BRAKE FLUID LEVEL SENSOR ELECTRICAL CONNECTOR
- 3 - BRAKE MASTER CYLINDER
- 4 - BRAKE FLUID RESERVOIR

(13) Install the brake master cylinder assembly (Fig. 3). Torque the retaining nuts to 29 N·m (250 in. lbs.).

(14) Install the brake lines on the master cylinder (Fig. 3). Torque the tube nuts to 17 N·m (145 in. lbs.).

(15) Connect the brake fluid level sensor electrical connector.

(16) Fill the brake fluid reservoir to specification.

(17) Bleed the brake system.

REMOVAL AND INSTALLATION (Continued)

**WARNING:** Be certain a firm brake pedal is achieved before attempting to move the vehicle.

**MASTER CYLINDER – R. H. D.**

**REMOVE**

- (1) Disconnect the negative battery cable.

**CAUTION:** Pump the brake pedal several times to relieve the vacuum in the power brake booster. This will prevent the booster from sucking in any contamination when the master cylinder is removed.

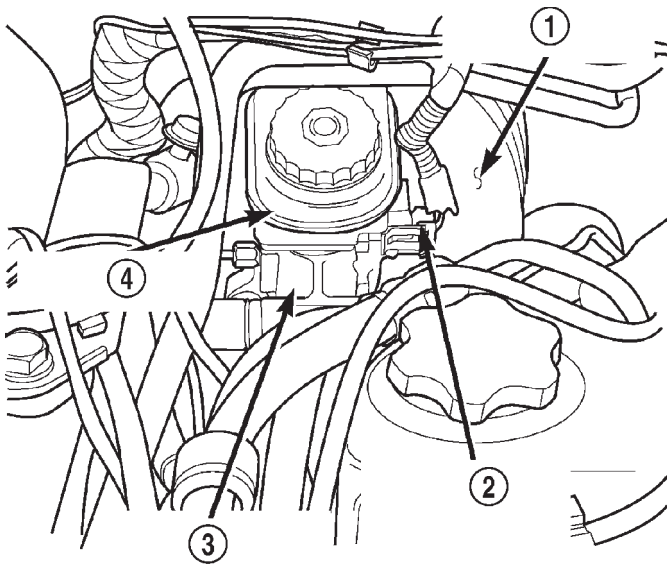

80bc4cb9

**Fig. 4 Master Cylinder – R. H. D.**

- 1 – POWER BRAKE VACUUM BOOSTER
- 2 – BRAKE FLUID LEVEL SENSOR ELECTRICAL CONNECTOR
- 3 – BRAKE MASTER CYLINDER
- 4 – BRAKE FLUID RESERVOIR

(2) Disconnect the brake fluid level sensor electrical connector (Fig. 4).

(3) Remove the brake lines from the master cylinder (Fig. 4).

(4) Remove the (2) master cylinder retaining nuts (Fig. 4).

(5) Slide the master cylinder assembly straight out of the power brake booster.

**INSTALLATION**

**CAUTION:** Be certain the rubber 0-ring vacuum seal is installed in the master cylinder mounting flange prior to installation.

**CAUTION:** If a new master cylinder is being installed, the cylinder must be bench bled prior to installation.

- (1) Slide the master cylinder assembly straight in the power brake booster.

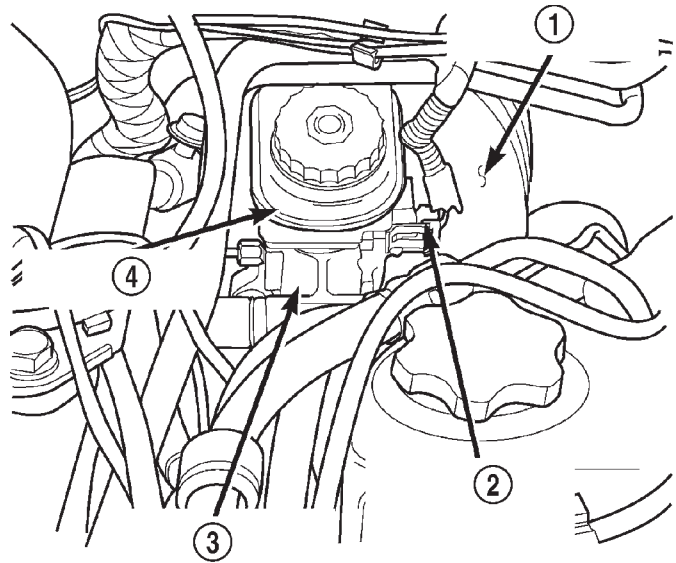

80bc4cb9

**Fig. 5 Master Cylinder – R. H. D.**

- 1 – POWER BRAKE VACUUM BOOSTER
- 2 – BRAKE FLUID LEVEL SENSOR ELECTRICAL CONNECTOR
- 3 – BRAKE MASTER CYLINDER
- 4 – BRAKE FLUID RESERVOIR

(2) Install the (2) master cylinder retaining nuts (Fig. 5). Torque the nuts to 28 N·m (250 in. lbs.).

(3) Install the brake lines on the master cylinder (Fig. 5). Torque the tube nuts to 17 N·m (145 in. lbs.).

(4) Connect the brake fluid level sensor electrical connector (Fig. 5).

(5) Fill the brake fluid reservoir (Fig. 5) to specification.

(6) Bleed the brake system.

**WARNING:** Be certain a firm brake pedal is achieved prior to attempting to operate the vehicle.

## SPECIFICATIONS

## TORQUE SPECIFICATIONS

<b>DESCRIPTION</b>	<b>TORQUE</b>
<b>Clutch Fluid Reservoir</b>	
Bolts . . . . .	7 N·m (62 in. lbs.)
<b>Coolant Reservoir on Dash Panel</b>	
Bolts . . . . .	7 N·m (62 in. lbs.)
<b>Brake Booster to Cowl Panel</b>	
Nuts . . . . .	29 N·m (250 in. lbs.)
<b>Brake Lines at Master Cylinder</b>	
Tube Nuts . . . . .	17 N·m (145 in. lbs.)
<b>Heater Core Coolant Supply Tubes</b>	
Bolts . . . . .	36 N·m (27 ft. lbs.)
<b>Master Cylinder to Vacuum Booster</b>	
Nuts . . . . .	29 N·m (250 in. lbs.)