

HEATING AND AIR CONDITIONING

TABLE OF CONTENTS

	page	page
REMOVAL AND INSTALLATION		
EVAPORATOR CORE – R. H. D.....	1	
HEATER CORE – R. H. D.....	3	
SPECIFICATIONS		
TORQUE SPECIFICATIONS.....		6

REMOVAL AND INSTALLATION

EVAPORATOR CORE – R. H. D.

REMOVAL

WARNING: ON VEHICLES EQUIPPED WITH AIR-BAGS, REFER TO GROUP 8M – PASSIVE RESTRAINT SYSTEMS BEFORE ATTEMPTING ANY STEERING WHEEL, STEERING COLUMN, OR INSTRUMENT PANEL COMPONENT DIAGNOSIS OR SERVICE. FAILURE TO TAKE THE PROPER PRECAUTIONS COULD RESULT IN ACCIDENTAL AIR-BAG DEPLOYMENT AND POSSIBLE PERSONAL INJURY.

WARNING: DO NOT OPEN THE RADIATOR DRAIN-COCK OR DISCONNECT COOLANT HOSES WHEN THE COOLING SYSTEM IS HOT AND UNDER PRESSURE. SERIOUS BURNS FROM COOLANT CAN OCCUR.

WARNING: READ ALL SAFETY PRECAUTIONS AND WARNINGS BEFORE PROCEEDING WITH THIS OPERATION.

- (1) Disconnect the negative battery cable.
- (2) Drain the cooling system. Refer to Group 7, Cooling System for the procedure.
- (3) Evacuate the refrigerant system.
- (4) Remove the instrument panel. Refer to Group 8E, Instrument Panel and Systems for the procedure.
- (5) Remove the refrigerant line retaining bolt from the expansion valve (Fig. 1). Remove the refrigerant lines from the expansion valve.
- (6) Disconnect the electrical connector from the bottom of the expansion valve (Fig. 1).
- (7) Remove the expansion valve retaining bolts and remove the valve from the vehicle.
- (8) Remove the heater core coolant supply hoses from the heater core (Fig. 2).

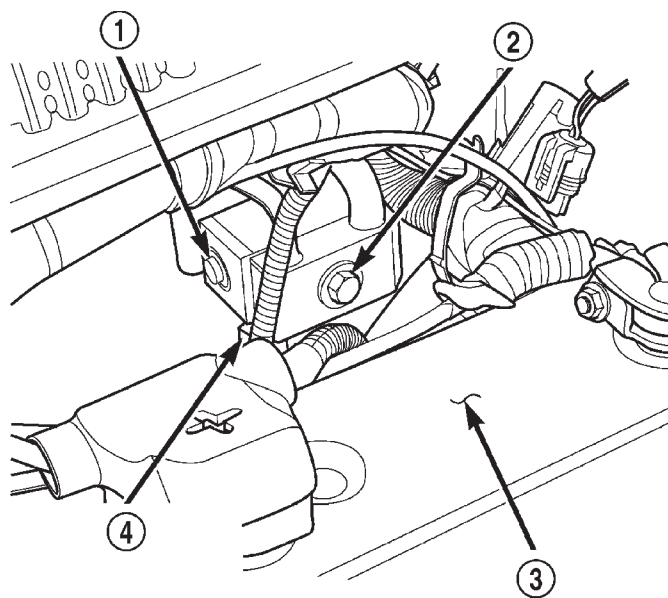

80bc4cbb

Fig. 1 Refrigerant Lines at Bulkhead

- 1 – EXPANSION VALVE
- 2 – REFRIGERANT LINE MANIFOLD RETAINING BOLT
- 3 – BATTERY
- 4 – LOW PRESSURE CUTOUT SWITCH ELECTRICAL CONNECTOR

- (9) Working from inside the engine compartment, remove the A/C-Heater housing retaining fasteners from the bulkhead.
- (10) Remove the A/C-Heater housing drain tube. Remove the spring clip and pull the hose from the housing nipple.
- (11) Working from inside the vehicle, remove the defroster duct from the A/C-Heater housing and body attachment point.
- (12) Remove the A/C-Heater housing retaining bolts.
- (13) Disconnect the electrical connectors from the A/C-Heater housing.
- (14) Remove the A/C-Heater housing from the vehicle and place the assembly on a bench.

REMOVAL AND INSTALLATION (Continued)

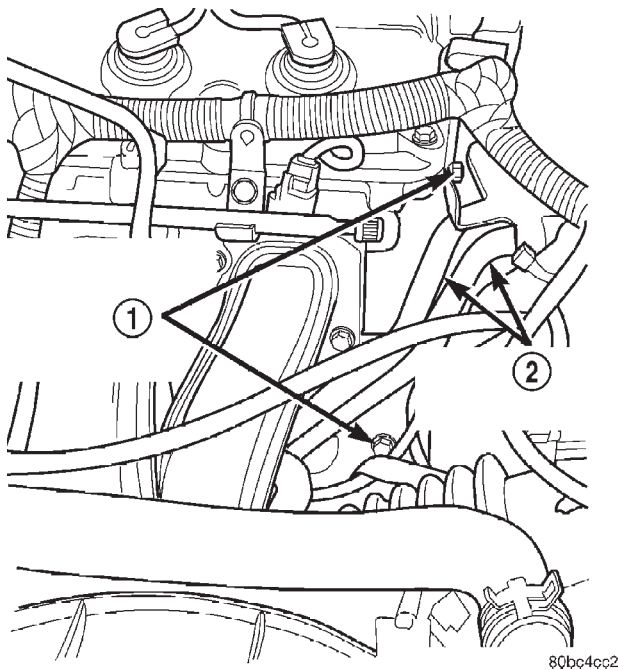
**Fig. 2 Heater Core Coolant Supply Lines**

- 1 - HEATER CORE COOLANT LINE SUPPORT BRACKETS BOLTS
- 2 - HEATER CORE COOLANT SUPPLY LINES

(15) Remove the heater core cover from the housing assembly.

(16) Remove the coolant lines from the heater core.

(17) Remove the screws necessary to disassemble the A/C-Heater housing assembly.

(18) Remove the evaporator coil from the A/C-Heater housing (Fig. 3).

INSTALLATION

NOTE: When the evaporator coil is replaced, some refrigerant oil will remain in the old evaporator. This oil must be replaced before the system is operated.

(1) Install the evaporator coil in the A/C-Heater housing (Fig. 4). Be certain all seals are replaced in their original positions.

(2) Reassemble the A/C-Heater housing.

(3) Install the housing in the vehicle and install the retaining bolts. Torque the bolts to 20 N·m (177 in. lbs.).

(4) Connect the electrical connectors on the A/C-Heater housing.

(5) Install the defroster duct on the A/C-Heater housing and secure at the body attachment point.

(6) Working from inside the engine compartment, install the A/C-Heater housing drain tube and retaining clip.

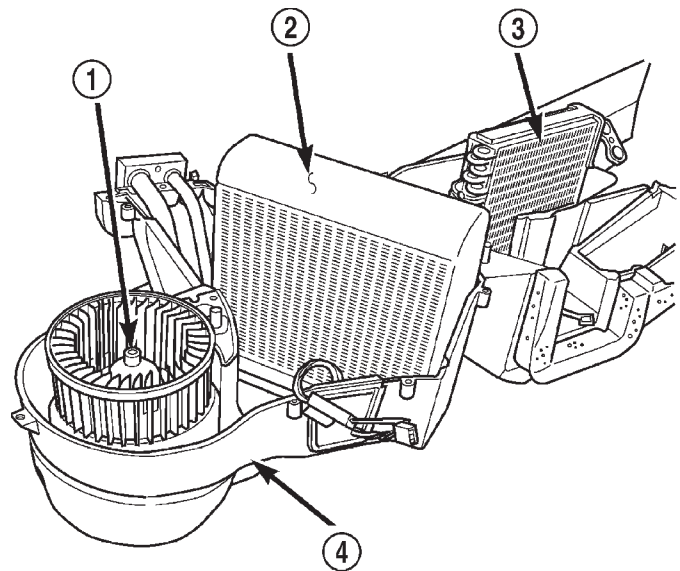

80bc4cbc

Fig. 3 A/C - Heater Housing

- 1 - BLOWER MOTOR
- 2 - EVAPORATOR COIL
- 3 - HEATER CORE
- 4 - A/C - HEATER HOUSING

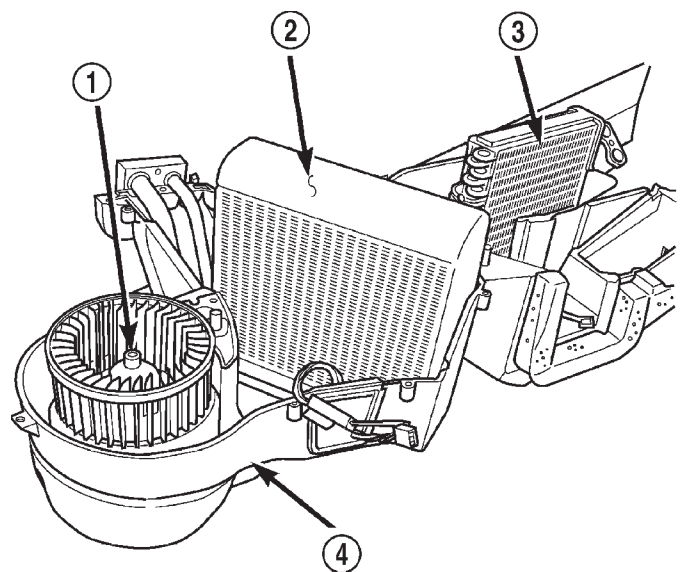

80bc4cbc

Fig. 4 A/C - Heater Housing

- 1 - BLOWER MOTOR
- 2 - EVAPORATOR COIL
- 3 - HEATER CORE
- 4 - A/C - HEATER HOUSING

REMOVAL AND INSTALLATION (Continued)

(7) Install the A/C-Heater housing retaining fasteners. Torque the fasteners to 20 N·m (177 in. lbs.).

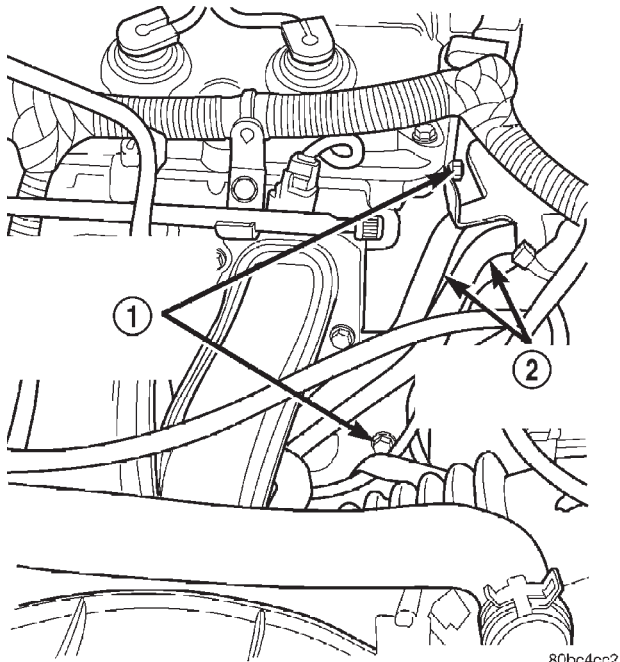

Fig. 5 Heater Core Coolant Supply Lines

- 1 - HEATER CORE COOLANT LINE SUPPORT BRACKETS BOLTS
- 2 - HEATER CORE COOLANT SUPPLY LINES

(8) Install the heater core coolant supply hoses on the heater core (Fig. 5).

(9) Install the expansion valve (Fig. 6), gasket and retaining bolts. Torque the bolts to 11 N·m (97 in. lbs.).

(10) Connect the electrical connector on the bottom of the expansion valve (Fig. 6).

(11) Install the refrigerant lines and retaining bolt (Fig. 6). Torque the bolt to 23 N·m (203 in. lbs.).

CAUTION: Be certain the refrigerant line sealing O-rings are well lubricated and free of tears.

(12) Install the instrument panel. Refer to Group 8E, Instrument Panel and Systems for the procedure.

(13) Charge the refrigerant system.

(14) Fill the cooling system. Refer to Group 7, Cooling System for the procedure.

(15) Connect the negative battery cable.

HEATER CORE - R. H. D.

REMOVAL

WARNING: ON VEHICLES EQUIPPED WITH AIR-BAGS, REFER TO GROUP 8M - PASSIVE RESTRAINT SYSTEMS BEFORE ATTEMPTING ANY STEERING WHEEL, STEERING COLUMN, OR

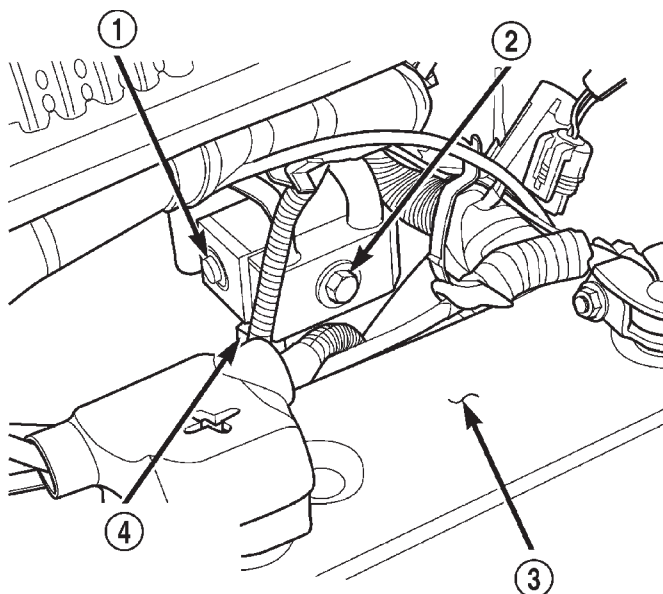

Fig. 6 Refrigerant Lines at Bulkhead

- 1 - EXPANSION VALVE
- 2 - REFRIGERANT LINE MANIFOLD RETAINING BOLT
- 3 - BATTERY
- 4 - LOW PRESSURE CUTOUT SWITCH ELECTRICAL CONNECTOR

INSTRUMENT PANEL COMPONENT DIAGNOSIS OR SERVICE. FAILURE TO TAKE THE PROPER PRECAUTIONS COULD RESULT IN ACCIDENTAL AIR-BAG DEPLOYMENT AND POSSIBLE PERSONAL INJURY.

WARNING: DO NOT OPEN THE RADIATOR DRAIN-COCK OR DISCONNECT COOLANT HOSES WHEN THE SYSTEM IS HOT AND UNDER PRESSURE. SERIOUS BURNS FROM COOLANT CAN OCCUR.

- (1) Disconnect the negative battery cable.
- (2) Drain the cooling system. Refer to Group 7, Cooling System for the procedure.
- (3) Evacuate the refrigerant system.
- (4) Remove the instrument panel. Refer to Group 8E, Instrument Panel and Systems for the procedure.
- (5) Remove the refrigerant line retaining bolt from the expansion valve (Fig. 7). Remove the refrigerant lines from the expansion valve.
- (6) Disconnect the electrical connector from the bottom of the expansion valve (Fig. 7).
- (7) Remove the expansion valve retaining bolts and remove the valve from the vehicle.

REMOVAL AND INSTALLATION (Continued)

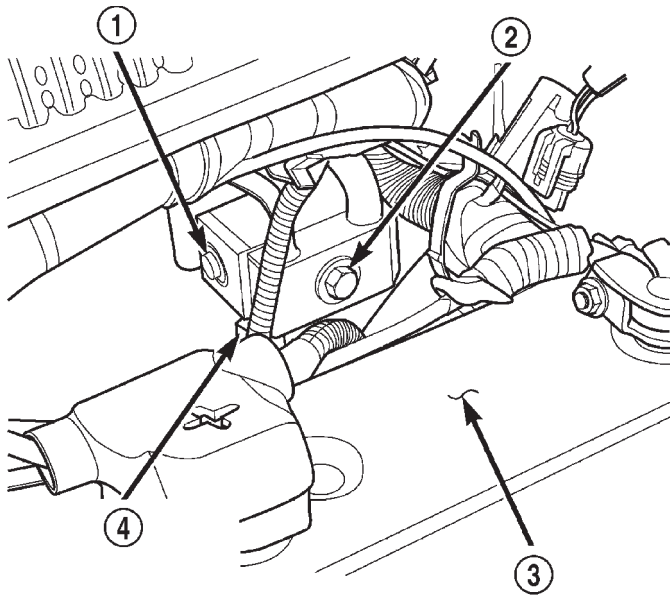

80bc4cbb

Fig. 7 Expansion Valve Position & Orientation

- 1 - EXPANSION VALVE
- 2 - REFRIGERANT LINE MANIFOLD RETAINING BOLT
- 3 - BATTERY
- 4 - LOW PRESSURE CUTOUT SWITCH ELECTRICAL CONNECTOR

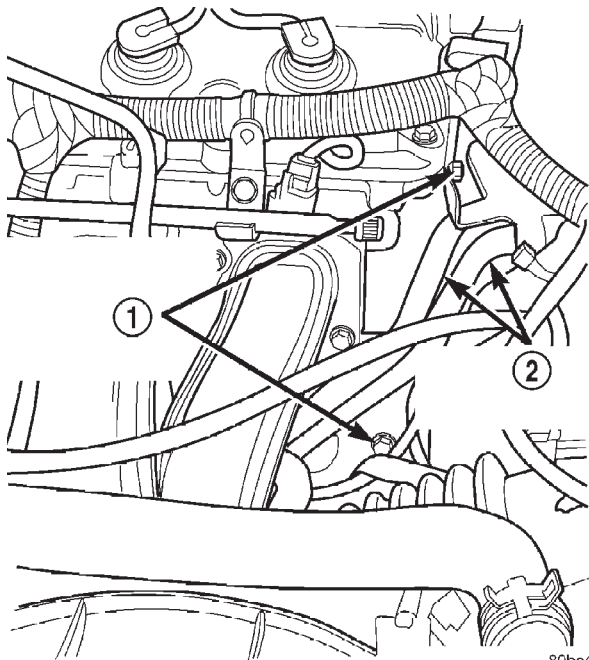

80bc4cc2

Fig. 8 Heater Core Coolant Supply Lines

- 1 - HEATER CORE COOLANT LINE SUPPORT BRACKETS BOLTS
- 2 - HEATER CORE COOLANT SUPPLY LINES

(8) Remove the heater core coolant supply hoses from the heater core (Fig. 8).

(9) Working from inside the engine compartment, remove the A/C-Heater housing retaining fasteners from the bulkhead.

(10) Remove the A/C-Heater housing drain tube. Remove the spring clip and pull the hose from the housing nipple.

(11) Working from inside the vehicle, remove the defroster duct from the A/C-Heater housing and body attachment point.

(12) Remove the A/C-Heater housing retaining bolts.

(13) Disconnect the electrical connectors from the A/C-Heater housing.

(14) Remove the A/C-Heater housing from the vehicle and place the assembly on a bench.

(15) Remove the heater core cover from the housing assembly.

(16) Remove the heater core coolant lines from the heater core.

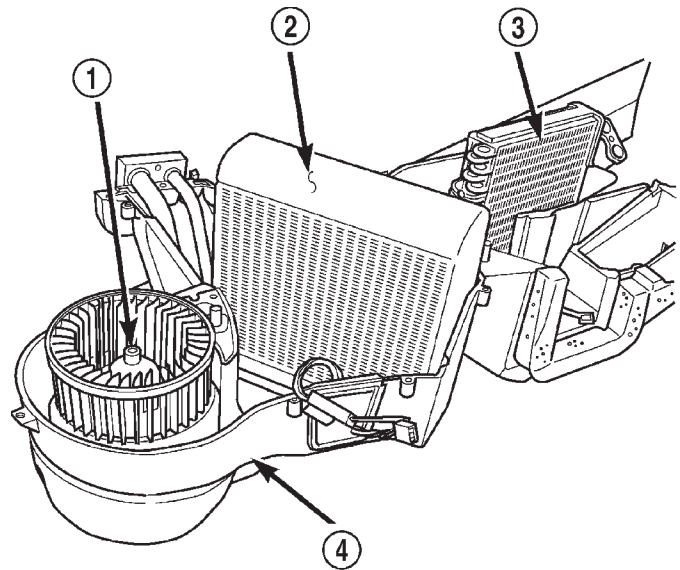

80bc4cbc

Fig. 9 Heater - A/C Housing

- 1 - BLOWER MOTOR
- 2 - EVAPORATOR COIL
- 3 - HEATER CORE
- 4 - A/C - HEATER HOUSING

(17) Remove the screws necessary to disassemble the A/C-Heater housing assembly (Fig. 9).

(18) Remove the heater core from the A/C-Heater housing (Fig. 9).

REMOVAL AND INSTALLATION (Continued)

INSTALLATION

(1) Install the heater core in the A/C-Heater housing.

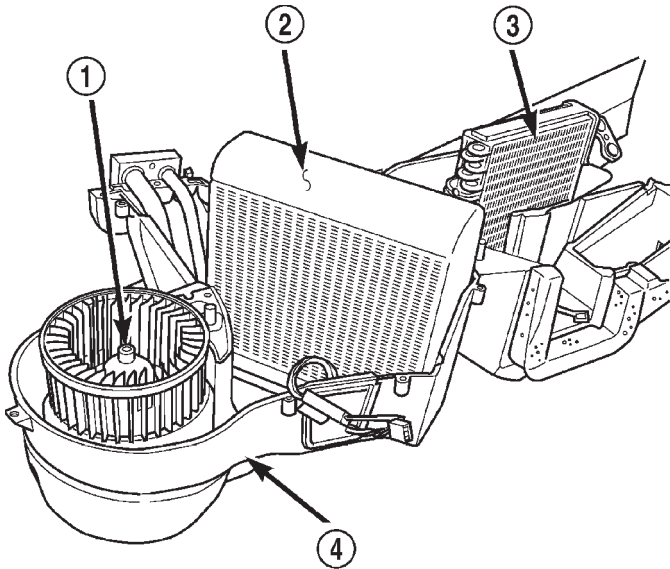

80bc4cbc

Fig. 10 Heater - A/C Housing

- 1 - BLOWER MOTOR
- 2 - EVAPORATOR COIL
- 3 - HEATER CORE
- 4 - A/C - HEATER HOUSING

- (2) Reassemble the A/C-Heater housing.
- (3) Install the housing in the vehicle and install the retaining bolts. Torque the bolts to 20 N·m (177 in. lbs.).
- (4) Connect the electrical connectors on the A/C-Heater housing.
- (5) Install the defroster duct on the A/C-Heater housing and secure at the body attachment point.
- (6) Install the A/C-Heater housing drain tube and retaining clip.
- (7) Install the A/C-Heater housing retaining fasteners. Torque the fasteners to 20 N·m (177 in. lbs.).
- (8) Install the heater core coolant supply hoses on the heater core (Fig. 11).
- (9) Install the expansion valve, gasket and retaining bolts. Torque the bolts to 11 N·m (97 in. lbs.).
- (10) Connect the electrical connector on the bottom of the expansion valve (Fig. 12).

CAUTION: Be certain the refrigerant line sealing O-rings are well lubricated and free of tears.

(11) Install the refrigerant lines and retaining bolt (Fig. 12). Torque the bolt to 23 N·m (203 in. lbs.).

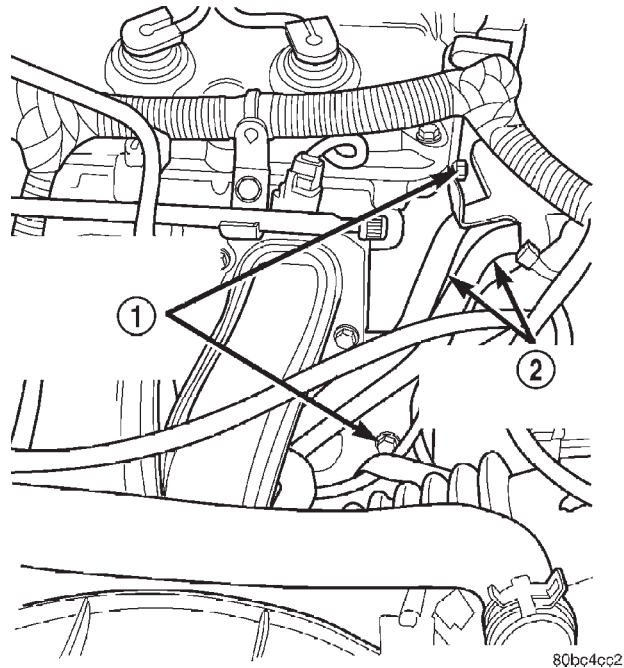

80bc4cc2

Fig. 11 Heater Core Coolant Supply Lines

- 1 - HEATER CORE COOLANT LINE SUPPORT BRACKETS BOLTS
- 2 - HEATER CORE COOLANT SUPPLY LINES

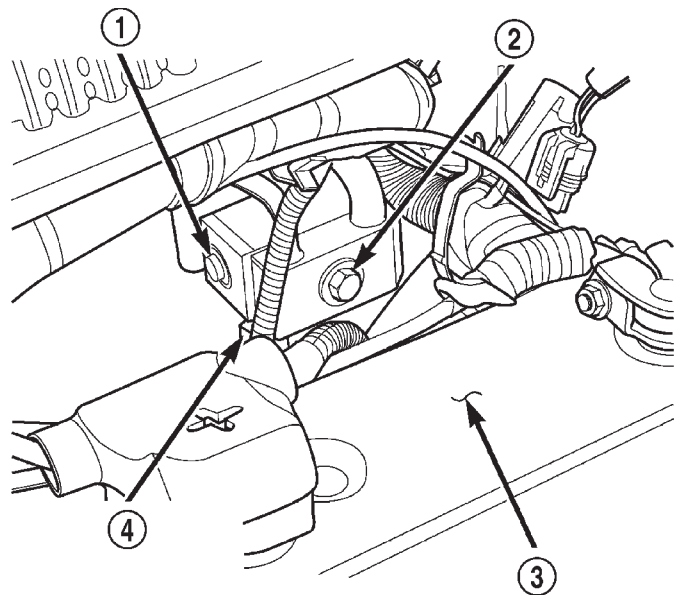

80bc4cbb

Fig. 12 Expansion Valve Position & Orientation

- 1 - EXPANSION VALVE
- 2 - REFRIGERANT LINE MANIFOLD RETAINING BOLT
- 3 - BATTERY
- 4 - LOW PRESSURE CUTOUT SWITCH ELECTRICAL CONNECTOR

REMOVAL AND INSTALLATION (Continued)

- (12) Install the instrument panel. Refer to Group 8E, Instrument Panel and Systems for the procedure.
- (13) Charge the refrigerant system.
- (14) Fill the cooling system. Refer to Group 7, Cooling System for the procedure.
- (15) Connect the negative battery cable.

SPECIFICATIONS

TORQUE SPECIFICATIONS

DESCRIPTION	TORQUE
A/C Heater Housing	
Bolts	20 N·m (177 in. lbs.)
Expansion Valve	
Bolts	11 N·m (97 in. lbs.)
Refrigeration Lines	
Bolt	23 N·m (203 in. lbs.)